



M25P16

16 Mbit, Low Voltage, Serial Flash Memory With 50 MHz SPI Bus Interface

FEATURES SUMMARY

- 16Mbit of Flash Memory
- Page Program (up to 256 Bytes) in 1.4ms (typical)
- Sector Erase (512 Kbit)
- Bulk Erase (16Mbit)
- 2.7 to 3.6V Single Supply Voltage
- SPI Bus Compatible Serial Interface
- 50MHz Clock Rate (maximum)
- Deep Power-down Mode 1 μ A (typical)
- Electronic Signatures
 - JEDEC Standard Two-Byte Signature (2015h)
 - RES Instruction, One-Byte, Signature (14h), for backward compatibility
- More than 100,000 Erase/Program Cycles per Sector
- More than 20 Year Data Retention

Figure 1. Packages

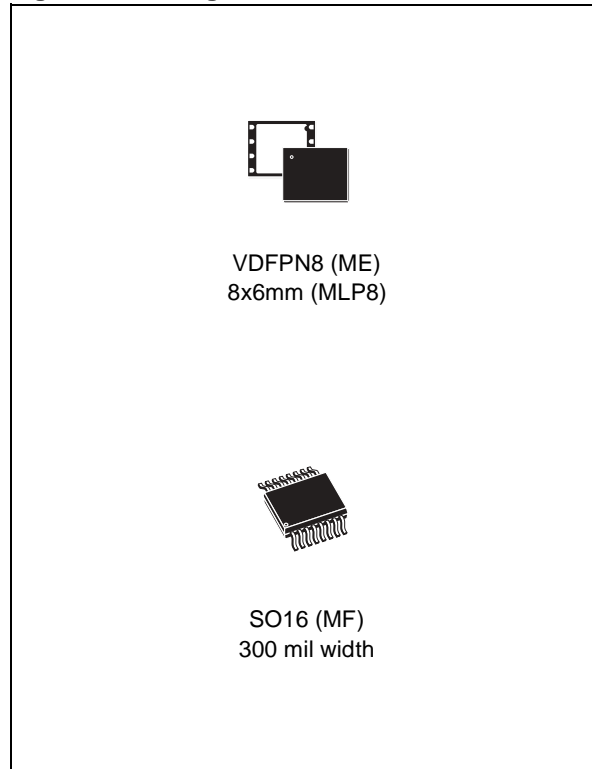

TABLE OF CONTENTS

| | |
|---|-----------|
| FEATURES SUMMARY | 1 |
| Figure 1. Packages | 1 |
| Figure 2. Logic Diagram | 5 |
| Table 1. Signal Names | 5 |
| Figure 3. VDFPN Connections | 5 |
| Figure 4. SO Connections | 5 |
| SIGNAL DESCRIPTION | 6 |
| Serial Data Output (Q) | 6 |
| Serial Data Input (D) | 6 |
| Serial Clock (C) | 6 |
| Chip Select (S) | 6 |
| Hold (HOLD) | 6 |
| Write Protect (W) | 6 |
| SPI MODES | 7 |
| Figure 5. Bus Master and Memory Devices on the SPI Bus | 7 |
| Figure 6. SPI Modes Supported | 7 |
| OPERATING FEATURES | 8 |
| Page Programming | 8 |
| Sector Erase and Bulk Erase | 8 |
| Polling During a Write, Program or Erase Cycle | 8 |
| Active Power, Stand-by Power and Deep Power-Down Modes | 8 |
| Status Register | 8 |
| WIP bit | 8 |
| WEL bit | 8 |
| BP2, BP1, BP0 bits | 8 |
| SRWD bit | 8 |
| Protection Modes | 9 |
| Table 2. Protected Area Sizes | 9 |
| Hold Condition | 10 |
| Figure 7. Hold Condition Activation | 10 |
| MEMORY ORGANIZATION | 11 |
| Figure 8. Block Diagram | 11 |
| Table 3. Memory Organization | 12 |
| INSTRUCTIONS | 13 |
| Table 4. Instruction Set | 13 |
| Write Enable (WREN) | 14 |
| Figure 9. Write Enable (WREN) Instruction Sequence | 14 |
| Write Disable (WRDI) | 14 |

| | |
|--|-----------|
| Figure 10. Write Disable (WRDI) Instruction Sequence | 14 |
| Read Identification (RDID) | 15 |
| Table 5. Read Identification (RDID) Data-Out Sequence | 15 |
| Figure 11. Read Identification (RDID) Instruction Sequence and Data-Out Sequence | 15 |
| Read Status Register (RDSR) | 16 |
| Table 6. Status Register Format | 16 |
| WIP bit | 16 |
| WEL bit | 16 |
| BP2, BP1, BP0 bits | 16 |
| SRWD bit | 16 |
| Figure 12. Read Status Register (RDSR) Instruction Sequence and Data-Out Sequence | 16 |
| Write Status Register (WRSR) | 17 |
| Figure 13. Write Status Register (WRSR) Instruction Sequence | 17 |
| Table 7. Protection Modes | 18 |
| Read Data Bytes (READ) | 19 |
| Figure 14. Read Data Bytes (READ) Instruction Sequence and Data-Out Sequence | 19 |
| Read Data Bytes at Higher Speed (FAST_READ) | 20 |
| Figure 15. Read Data Bytes at Higher Speed (FAST_READ) Instruction Sequence and Data-Out Sequence | 20 |
| Page Program (PP) | 21 |
| Figure 16. Page Program (PP) Instruction Sequence | 21 |
| Sector Erase (SE) | 22 |
| Figure 17. Sector Erase (SE) Instruction Sequence | 22 |
| Bulk Erase (BE) | 23 |
| Figure 18. Bulk Erase (BE) Instruction Sequence | 23 |
| Deep Power-down (DP) | 24 |
| Figure 19. Deep Power-down (DP) Instruction Sequence | 24 |
| Release from Deep Power-down and Read Electronic Signature (RES) | 25 |
| Figure 20. Release from Deep Power-down and Read Electronic Signature (RES) Instruction Sequence and Data-Out Sequence | 25 |
| Figure 21. Release from Deep Power-down (RES) Instruction Sequence | 26 |
| POWER-UP AND POWER-DOWN | 27 |
| Figure 22. Power-up Timing | 27 |
| Table 8. Power-Up Timing and VWI Threshold | 28 |
| INITIAL DELIVERY STATE | 28 |
| MAXIMUM RATING | 29 |
| Table 9. Absolute Maximum Ratings | 29 |
| DC AND AC PARAMETERS | 30 |
| Table 10. Operating Conditions | 30 |
| Table 11. AC Measurement Conditions | 30 |
| Figure 23. AC Measurement I/O Waveform | 30 |
| Table 12. Capacitance | 30 |

Table 13. DC Characteristics 31

Table 14. AC Characteristics 31

Figure 24. Serial Input Timing 33

Figure 25. Write Protect Setup and Hold Timing during WRSR when SRWD=1 33

Figure 26. Hold Timing 34

Figure 27. Output Timing 34

PACKAGE MECHANICAL 35

Figure 28. MLP8, 8-lead Very thin Dual Flat Package No lead, 8x6mm, Package Outline 35

Table 15. MLP8, 8-lead Very thin Dual Flat Package No lead, 8x6mm, Package Mechanical Data 35

Figure 29. SO16 wide – 16-lead Plastic Small Outline, 300 mils body width, Package Outline . . . 36

Table 16. SO16 wide – 16-lead Plastic Small Outline, 300 mils body width, Mechanical Data . . . 36

PART NUMBERING 37

Table 17. Ordering Information Scheme 37

REVISION HISTORY 38

Table 18. Document Revision History 38

SUMMARY DESCRIPTION

The M25P16 is a 16Mbit (2M x 8) Serial Flash Memory, with advanced write protection mechanisms, accessed by a high speed SPI-compatible bus.

The memory can be programmed 1 to 256 bytes at a time, using the Page Program instruction.

The memory is organized as 32 sectors, each containing 256 pages. Each page is 256 bytes wide. Thus, the whole memory can be viewed as consisting of 8192 pages, or 2,097,152 bytes.

The whole memory can be erased using the Bulk Erase instruction, or a sector at a time, using the Sector Erase instruction.

Figure 2. Logic Diagram

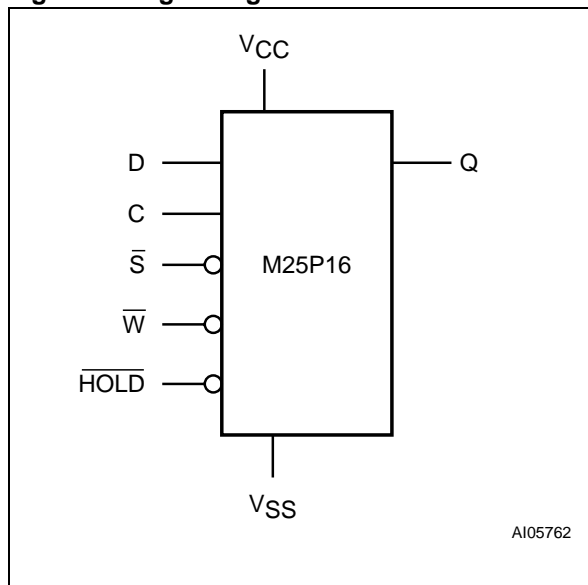
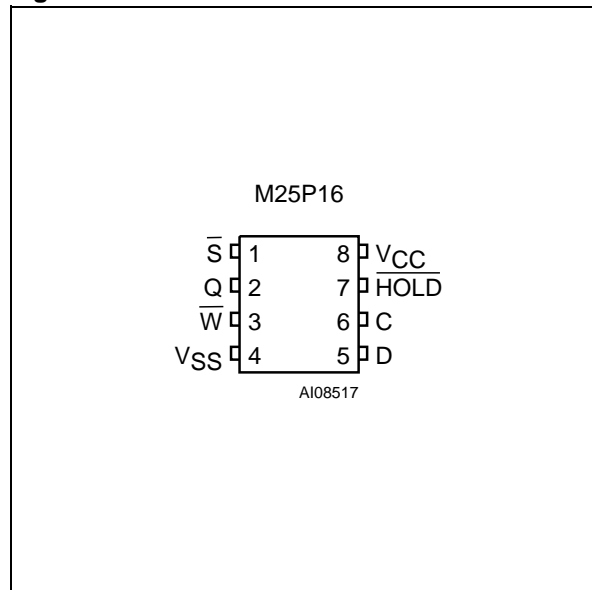

Table 1. Signal Names

| | |
|-----------------|--------------------|
| C | Serial Clock |
| D | Serial Data Input |
| Q | Serial Data Output |
| S̄ | Chip Select |
| W̄ | Write Protect |
| HOLD | Hold |
| V _{CC} | Supply Voltage |
| V _{SS} | Ground |

Figure 3. VDFPN Connections



- Note: 1. There is an exposed die paddle on the underside of the MLP8 package. This is pulled, internally, to V_{SS}, and must not be allowed to be connected to any other voltage or signal line on the PCB.
 2. See [PACKAGE MECHANICAL](#) section for package dimensions, and how to identify pin-1.

Figure 4. SO Connections

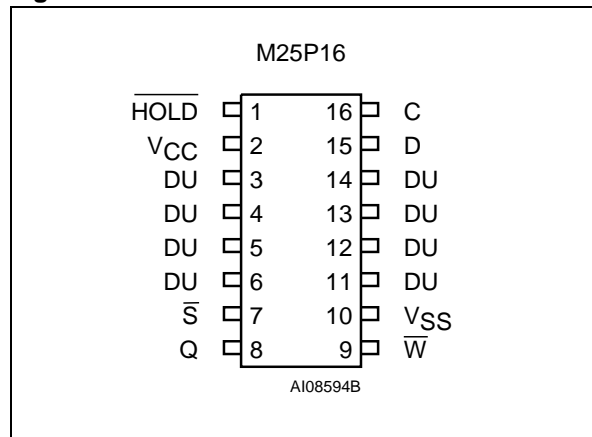

- Note: 1. DU = Don't Use
 2. See [PACKAGE MECHANICAL](#) section for package dimensions, and how to identify pin-1.

SIGNAL DESCRIPTION

Serial Data Output (Q). This output signal is used to transfer data serially out of the device. Data is shifted out on the falling edge of Serial Clock (C).

Serial Data Input (D). This input signal is used to transfer data serially into the device. It receives instructions, addresses, and the data to be programmed. Values are latched on the rising edge of Serial Clock (C).

Serial Clock (C). This input signal provides the timing of the serial interface. Instructions, addresses, or data present at Serial Data Input (D) are latched on the rising edge of Serial Clock (C). Data on Serial Data Output (Q) changes after the falling edge of Serial Clock (C).

Chip Select (\overline{S}). When this input signal is High, the device is deselected and Serial Data Output (Q) is at high impedance. Unless an internal Program, Erase or Write Status Register cycle is in progress, the device will be in the Standby mode

(this is not the Deep Power-down mode). Driving Chip Select (\overline{S}) Low enables the device, placing it in the active power mode.

After Power-up, a falling edge on Chip Select (\overline{S}) is required prior to the start of any instruction.

Hold (\overline{HOLD}). The Hold (\overline{HOLD}) signal is used to pause any serial communications with the device without deselecting the device.

During the Hold condition, the Serial Data Output (Q) is high impedance, and Serial Data Input (D) and Serial Clock (C) are Don't Care.

To start the Hold condition, the device must be selected, with Chip Select (\overline{S}) driven Low.

Write Protect (\overline{W}). The main purpose of this input signal is to freeze the size of the area of memory that is protected against program or erase instructions (as specified by the values in the BP2, BP1 and BP0 bits of the Status Register).

SPI MODES

These devices can be driven by a microcontroller with its SPI peripheral running in either of the two following modes:

- CPOL=0, CPHA=0
- CPOL=1, CPHA=1

For these two modes, input data is latched in on the rising edge of Serial Clock (C), and output data

is available from the falling edge of Serial Clock (C).

The difference between the two modes, as shown in Figure 6., is the clock polarity when the bus master is in Stand-by mode and not transferring data:

- C remains at 0 for (CPOL=0, CPHA=0)
- C remains at 1 for (CPOL=1, CPHA=1)

Figure 5. Bus Master and Memory Devices on the SPI Bus

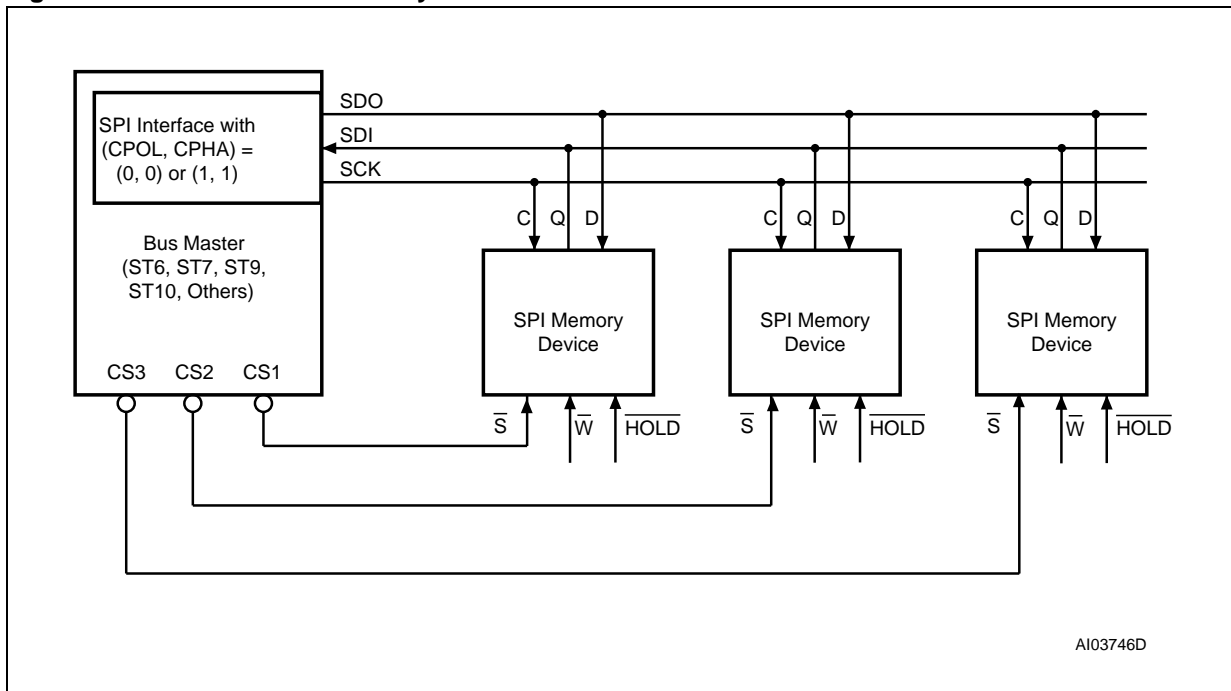

Note: The Write Protect (\overline{W}) and Hold (\overline{HOLD}) signals should be driven, High or Low as appropriate.

Figure 6. SPI Modes Supported

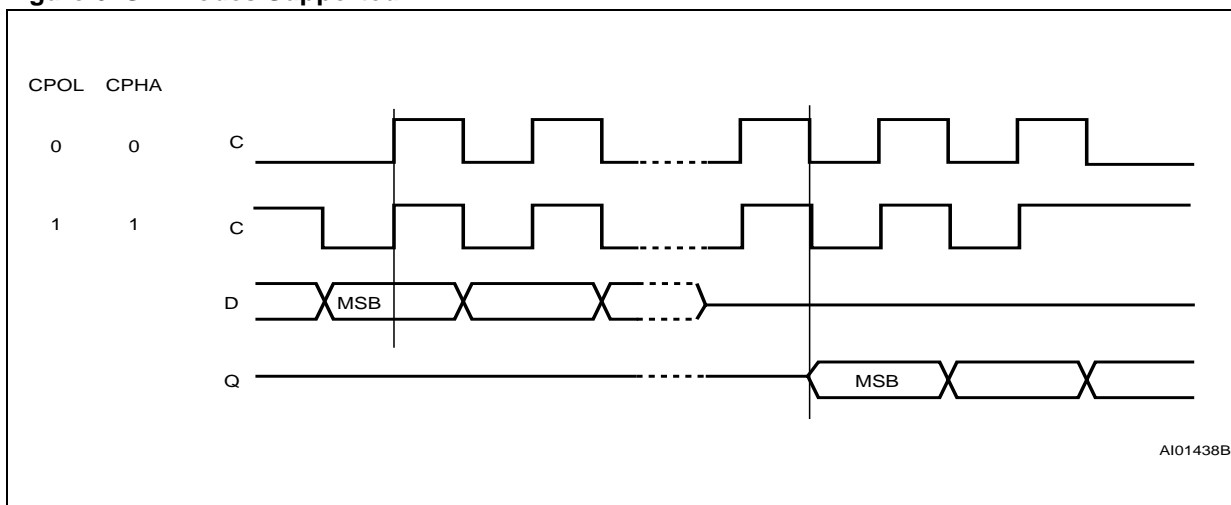

OPERATING FEATURES

Page Programming

To program one data byte, two instructions are required: Write Enable (WREN), which is one byte, and a Page Program (PP) sequence, which consists of four bytes plus data. This is followed by the internal Program cycle (of duration t_{PP}).

To spread this overhead, the Page Program (PP) instruction allows up to 256 bytes to be programmed at a time (changing bits from 1 to 0), provided that they lie in consecutive addresses on the same page of memory.

Sector Erase and Bulk Erase

The Page Program (PP) instruction allows bits to be reset from 1 to 0. Before this can be applied, the bytes of memory need to have been erased to all 1s (FFh). This can be achieved either a sector at a time, using the Sector Erase (SE) instruction, or throughout the entire memory, using the Bulk Erase (BE) instruction. This starts an internal Erase cycle (of duration t_{SE} or t_{BE}).

The Erase instruction must be preceded by a Write Enable (WREN) instruction.

Polling During a Write, Program or Erase Cycle

A further improvement in the time to Write Status Register (WRSR), Program (PP) or Erase (SE or BE) can be achieved by not waiting for the worst case delay (t_W , t_{PP} , t_{SE} , or t_{BE}). The Write In Progress (WIP) bit is provided in the Status Register so that the application program can monitor its value, polling it to establish when the previous Write cycle, Program cycle or Erase cycle is complete.

Active Power, Stand-by Power and Deep Power-Down Modes

When Chip Select (\overline{S}) is Low, the device is enabled, and in the Active Power mode.

When Chip Select (\overline{S}) is High, the device is disabled, but could remain in the Active Power mode until all internal cycles have completed (Program,

Erase, Write Status Register). The device then goes in to the Stand-by Power mode. The device consumption drops to I_{CC1} .

The Deep Power-down mode is entered when the specific instruction (the Enter Deep Power-down Mode (DP) instruction) is executed. The device consumption drops further to I_{CC2} . The device remains in this mode until another specific instruction (the Release from Deep Power-down Mode and Read Electronic Signature (RES) instruction) is executed.

All other instructions are ignored while the device is in the Deep Power-down mode. This can be used as an extra software protection mechanism, when the device is not in active use, to protect the device from inadvertent Write, Program or Erase instructions.

Status Register

The Status Register contains a number of status and control bits that can be read or set (as appropriate) by specific instructions.

WIP bit. The Write In Progress (WIP) bit indicates whether the memory is busy with a Write Status Register, Program or Erase cycle.

WEL bit. The Write Enable Latch (WEL) bit indicates the status of the internal Write Enable Latch.

BP2, BP1, BP0 bits. The Block Protect (BP2, BP1, BP0) bits are non-volatile. They define the size of the area to be software protected against Program and Erase instructions.

SRWD bit. The Status Register Write Disable (SRWD) bit is operated in conjunction with the Write Protect (\overline{W}) signal. The Status Register Write Disable (SRWD) bit and Write Protect (\overline{W}) signal allow the device to be put in the Hardware Protected mode. In this mode, the non-volatile bits of the Status Register (SRWD, BP2, BP1, BP0) become read-only bits.

Protection Modes

The environments where non-volatile memory devices are used can be very noisy. No SPI device can operate correctly in the presence of excessive noise. To help combat this, the M25P16 boasts the following data protection mechanisms:

- Power-On Reset and an internal timer (t_{PUW}) can provide protection against inadvertent changes while the power supply is outside the operating specification.
- Program, Erase and Write Status Register instructions are checked that they consist of a number of clock pulses that is a multiple of eight, before they are accepted for execution.
- All instructions that modify data must be preceded by a Write Enable (WREN) instruction to set the Write Enable Latch (WEL) bit. This bit is returned to its reset state by the following events:
 - Power-up
 - Write Disable (WRDI) instruction completion
 - Write Status Register (WRSR) instruction completion
 - Page Program (PP) instruction completion
 - Sector Erase (SE) instruction completion
 - Bulk Erase (BE) instruction completion
- The Block Protect (BP2, BP1, BP0) bits allow part of the memory to be configured as read-only. This is the Software Protected Mode (SPM).
- The Write Protect (\overline{W}) signal allows the Block Protect (BP2, BP1, BP0) bits and Status Register Write Disable (SRWD) bit to be protected. This is the Hardware Protected Mode (HPM).
- In addition to the low power consumption feature, the Deep Power-down mode offers extra software protection from inadvertent Write, Program and Erase instructions, as all instructions are ignored except one particular instruction (the Release from Deep Power-down instruction).

Table 2. Protected Area Sizes

| Status Register Content | | | Memory Content | |
|-------------------------|---------|---------|--|--|
| BP2 Bit | BP1 Bit | BP0 Bit | Protected Area | Unprotected Area |
| 0 | 0 | 0 | none | All sectors ¹ (32 sectors: 0 to 31) |
| 0 | 0 | 1 | Upper 32nd (Sector 31) | Lower 31/32nds (31 sectors: 0 to 30) |
| 0 | 1 | 0 | Upper sixteenth (two sectors: 30 and 31) | Lower 15/16ths (30 sectors: 0 to 29) |
| 0 | 1 | 1 | Upper eighth (four sectors: 28 to 31) | Lower seven-eighths (28 sectors: 0 to 27) |
| 1 | 0 | 0 | Upper quarter (eight sectors: 24 to 31) | Lower three-quarters (24 sectors: 0 to 23) |
| 1 | 0 | 1 | Upper half (sixteen sectors: 16 to 31) | Lower half (16 sectors: 0 to 15) |
| 1 | 1 | 0 | All sectors (32 sectors: 0 to 31) | none |
| 1 | 1 | 1 | All sectors (32 sectors: 0 to 31) | none |

Note: 1. The device is ready to accept a Bulk Erase instruction if, and only if, all Block Protect (BP2, BP1, BP0) are 0.

Hold Condition

The Hold ($\overline{\text{HOLD}}$) signal is used to pause any serial communications with the device without resetting the clocking sequence. However, taking this signal Low does not terminate any Write Status Register, Program or Erase cycle that is currently in progress.

To enter the Hold condition, the device must be selected, with Chip Select ($\overline{\text{S}}$) Low.

The Hold condition starts on the falling edge of the Hold ($\overline{\text{HOLD}}$) signal, provided that this coincides with Serial Clock (C) being Low (as shown in Figure 7.).

The Hold condition ends on the rising edge of the Hold ($\overline{\text{HOLD}}$) signal, provided that this coincides with Serial Clock (C) being Low.

If the falling edge does not coincide with Serial Clock (C) being Low, the Hold condition starts after Serial Clock (C) next goes Low. Similarly, if the

rising edge does not coincide with Serial Clock (C) being Low, the Hold condition ends after Serial Clock (C) next goes Low. (This is shown in Figure 7.).

During the Hold condition, the Serial Data Output (Q) is high impedance, and Serial Data Input (D) and Serial Clock (C) are Don't Care.

Normally, the device is kept selected, with Chip Select ($\overline{\text{S}}$) driven Low, for the whole duration of the Hold condition. This is to ensure that the state of the internal logic remains unchanged from the moment of entering the Hold condition.

If Chip Select ($\overline{\text{S}}$) goes High while the device is in the Hold condition, this has the effect of resetting the internal logic of the device. To restart communication with the device, it is necessary to drive Hold ($\overline{\text{HOLD}}$) High, and then to drive Chip Select ($\overline{\text{S}}$) Low. This prevents the device from going back to the Hold condition.

Figure 7. Hold Condition Activation

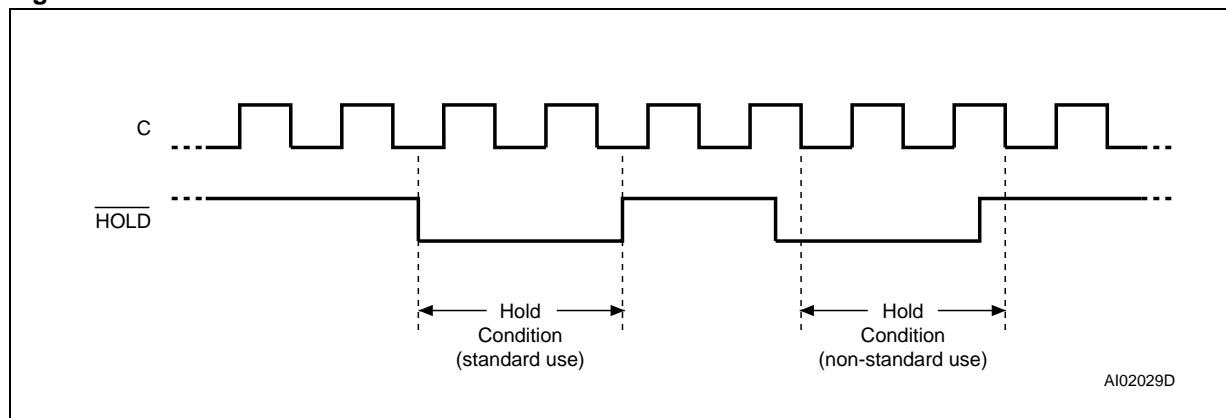

MEMORY ORGANIZATION

The memory is organized as:

- 2,097,152 bytes (8 bits each)
- 32 sectors (512 Kbits, 65536 bytes each)
- 8192 pages (256 bytes each).

Each page can be individually programmed (bits are programmed from 1 to 0). The device is Sector or Bulk Erasable (bits are erased from 0 to 1) but not Page Erasable.

Figure 8. Block Diagram

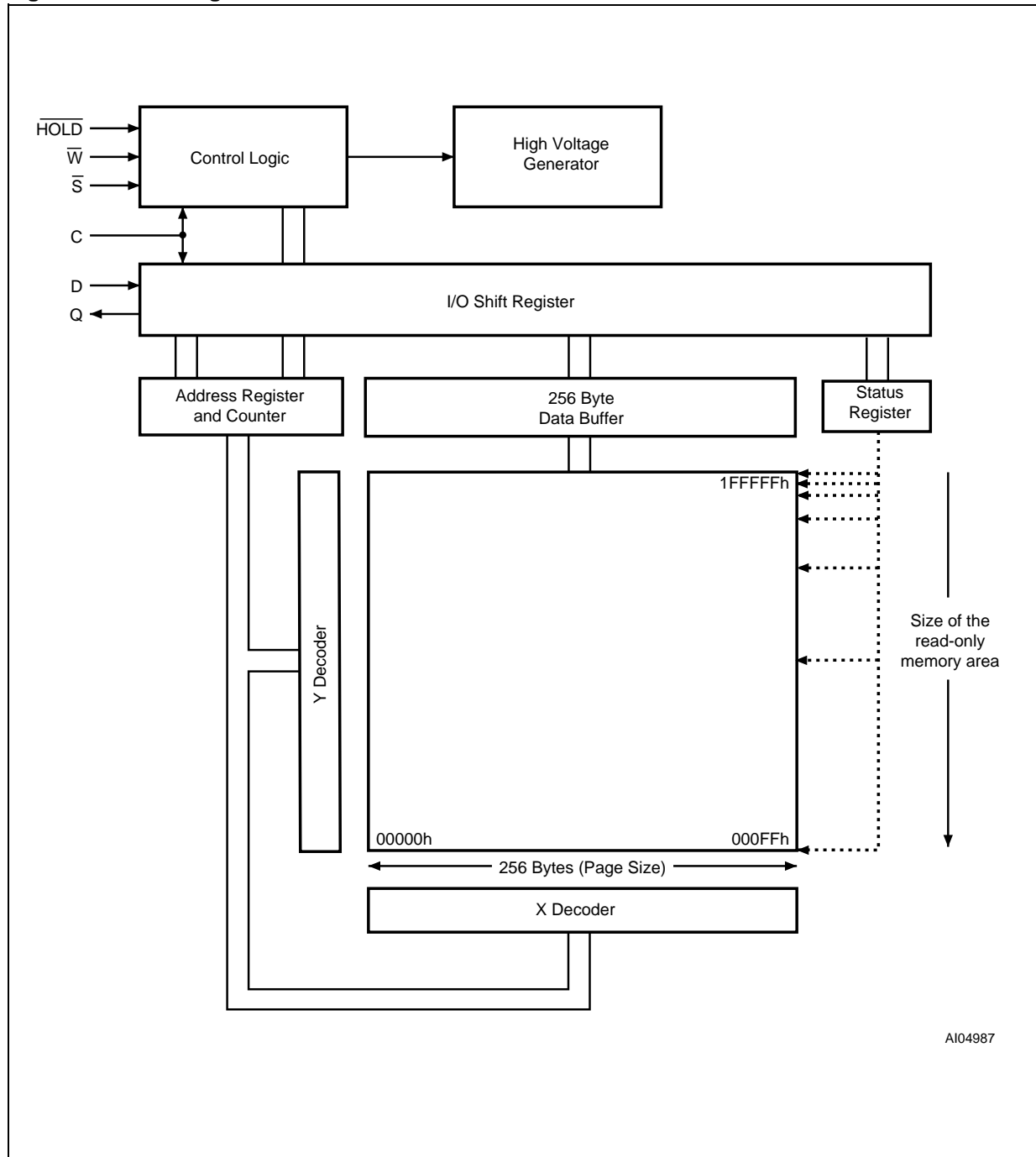

A104987

Table 3. Memory Organization

| Sector | Address Range | |
|--------|---------------|-----------|
| 31 | 1F0000h | 1FFFFFFh |
| 30 | 1E0000h | 1EFFFFFFh |
| 29 | 1D0000h | 1DFFFFFFh |
| 28 | 1C0000h | 1CFFFFFFh |
| 27 | 1B0000h | 1BFFFFFFh |
| 26 | 1A0000h | 1AFFFFFFh |
| 25 | 190000h | 19FFFFFFh |
| 24 | 180000h | 18FFFFFFh |
| 23 | 170000h | 17FFFFFFh |
| 22 | 160000h | 16FFFFFFh |
| 21 | 150000h | 15FFFFFFh |
| 20 | 140000h | 14FFFFFFh |
| 19 | 130000h | 13FFFFFFh |
| 18 | 120000h | 12FFFFFFh |
| 17 | 110000h | 11FFFFFFh |
| 16 | 100000h | 10FFFFFFh |
| 15 | 0F0000h | 0FFFFFFh |
| 14 | 0E0000h | 0EFFFFFFh |
| 13 | 0D0000h | 0DFFFFFFh |
| 12 | 0C0000h | 0CFFFFFFh |
| 11 | 0B0000h | 0BFFFFFFh |
| 10 | 0A0000h | 0AFFFFFFh |
| 9 | 090000h | 09FFFFFFh |
| 8 | 080000h | 08FFFFFFh |
| 7 | 070000h | 07FFFFFFh |
| 6 | 060000h | 06FFFFFFh |
| 5 | 050000h | 05FFFFFFh |
| 4 | 040000h | 04FFFFFFh |
| 3 | 030000h | 03FFFFFFh |
| 2 | 020000h | 02FFFFFFh |
| 1 | 010000h | 01FFFFFFh |
| 0 | 000000h | 00FFFFFFh |

INSTRUCTIONS

All instructions, addresses and data are shifted in and out of the device, most significant bit first.

Serial Data Input (D) is sampled on the first rising edge of Serial Clock (C) after Chip Select (\bar{S}) is driven Low. Then, the one-byte instruction code must be shifted in to the device, most significant bit first, on Serial Data Input (D), each bit being latched on the rising edges of Serial Clock (C).

The instruction set is listed in [Table 4.](#)

Every instruction sequence starts with a one-byte instruction code. Depending on the instruction, this might be followed by address bytes, or by data bytes, or by both or none.

In the case of a Read Data Bytes (READ), Read Data Bytes at Higher Speed (Fast_Read), Read Status Register (RDSR), Read Identification (RDID) or Release from Deep Power-down, and Read Electronic Signature (RES) instruction, the shifted-in instruction sequence is followed by a

data-out sequence. Chip Select (\bar{S}) can be driven High after any bit of the data-out sequence is being shifted out.

In the case of a Page Program (PP), Sector Erase (SE), Bulk Erase (BE), Write Status Register (WRSR), Write Enable (WREN), Write Disable (WRDI) or Deep Power-down (DP) instruction, Chip Select (\bar{S}) must be driven High exactly at a byte boundary, otherwise the instruction is rejected, and is not executed. That is, Chip Select (\bar{S}) must be driven High when the number of clock pulses after Chip Select (\bar{S}) being driven Low is an exact multiple of eight.

All attempts to access the memory array during a Write Status Register cycle, Program cycle or Erase cycle are ignored, and the internal Write Status Register cycle, Program cycle or Erase cycle continues unaffected.

Table 4. Instruction Set

| Instruction | Description | One-byte Instruction Code | | Address Bytes | Dummy Bytes | Data Bytes |
|-------------|---|---------------------------|-----|---------------|-------------|------------|
| WREN | Write Enable | 0000 0110 | 06h | 0 | 0 | 0 |
| WRDI | Write Disable | 0000 0100 | 04h | 0 | 0 | 0 |
| RDID | Read Identification | 1001 1111 | 9Fh | 0 | 0 | 1 to 3 |
| RDSR | Read Status Register | 0000 0101 | 05h | 0 | 0 | 1 to ∞ |
| WRSR | Write Status Register | 0000 0001 | 01h | 0 | 0 | 1 |
| READ | Read Data Bytes | 0000 0011 | 03h | 3 | 0 | 1 to ∞ |
| FAST_READ | Read Data Bytes at Higher Speed | 0000 1011 | 0Bh | 3 | 1 | 1 to ∞ |
| PP | Page Program | 0000 0010 | 02h | 3 | 0 | 1 to 256 |
| SE | Sector Erase | 1101 1000 | D8h | 3 | 0 | 0 |
| BE | Bulk Erase | 1100 0111 | C7h | 0 | 0 | 0 |
| DP | Deep Power-down | 1011 1001 | B9h | 0 | 0 | 0 |
| RES | Release from Deep Power-down, and Read Electronic Signature | 1010 1011 | ABh | 0 | 3 | 1 to ∞ |
| | Release from Deep Power-down | | | 0 | 0 | 0 |

Write Enable (WREN)

The Write Enable (WREN) instruction (Figure 9.) sets the Write Enable Latch (WEL) bit.

The Write Enable Latch (WEL) bit must be set prior to every Page Program (PP), Sector Erase

(SE), Bulk Erase (BE) and Write Status Register (WRSR) instruction.

The Write Enable (WREN) instruction is entered by driving Chip Select (\overline{S}) Low, sending the instruction code, and then driving Chip Select (\overline{S}) High.

Figure 9. Write Enable (WREN) Instruction Sequence

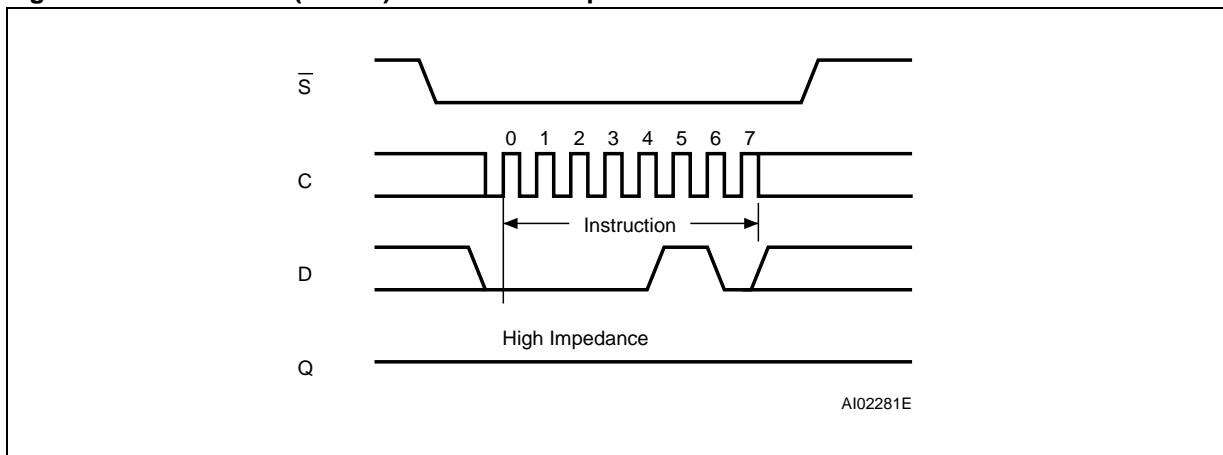

Write Disable (WRDI)

The Write Disable (WRDI) instruction (Figure 10.) resets the Write Enable Latch (WEL) bit.

The Write Disable (WRDI) instruction is entered by driving Chip Select (\overline{S}) Low, sending the instruction code, and then driving Chip Select (\overline{S}) High.

The Write Enable Latch (WEL) bit is reset under the following conditions:

- Power-up
- Write Disable (WRDI) instruction completion
- Write Status Register (WRSR) instruction completion
- Page Program (PP) instruction completion
- Sector Erase (SE) instruction completion
- Bulk Erase (BE) instruction completion

Figure 10. Write Disable (WRDI) Instruction Sequence

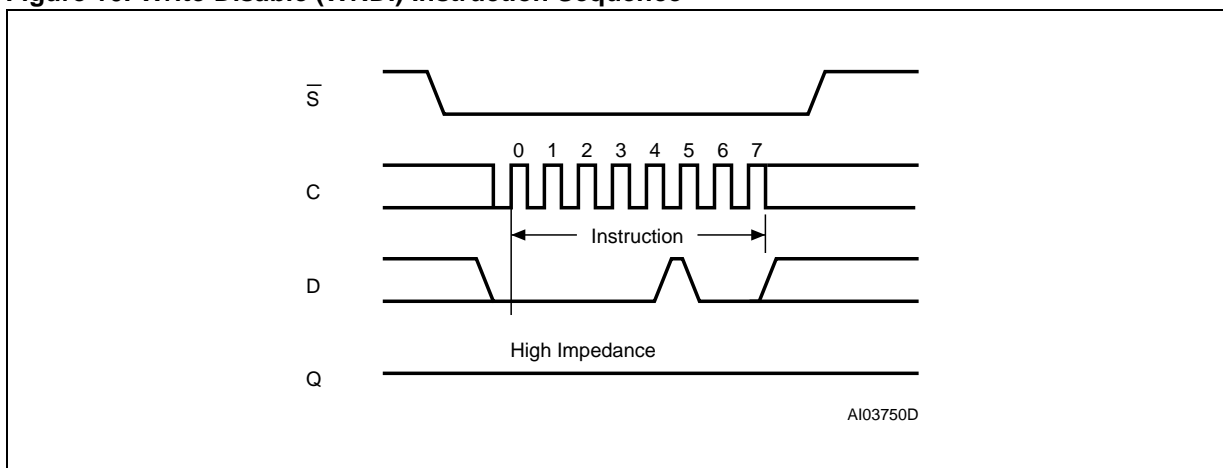

Read Identification (RDID)

The Read Identification (RDID) instruction allows the 8-bit manufacturer identification to be read, followed by two bytes of device identification. The manufacturer identification is assigned by JEDEC, and has the value 20h for STMicroelectronics. The device identification is assigned by the device manufacturer, and indicates the memory type in the first byte (20h), and the memory capacity of the device in the second byte (15h).

Any Read Identification (RDID) instruction while an Erase or Program cycle is in progress, is not decoded, and has no effect on the cycle that is in progress.

The device is first selected by driving Chip Select (\bar{S}) Low. Then, the 8-bit instruction code for the in-

struction is shifted in. This is followed by the 24-bit device identification, stored in the memory, being shifted out on Serial Data Output (Q), each bit being shifted out during the falling edge of Serial Clock (C).

The instruction sequence is shown in Figure 11..

The Read Identification (RDID) instruction is terminated by driving Chip Select (\bar{S}) High at any time during data output.

When Chip Select (\bar{S}) is driven High, the device is put in the Stand-by Power mode. Once in the Stand-by Power mode, the device waits to be selected, so that it can receive, decode and execute instructions.

Table 5. Read Identification (RDID) Data-Out Sequence

| Manufacturer Identification | Device Identification | |
|-----------------------------|-----------------------|-----------------|
| | Memory Type | Memory Capacity |
| 20h | 20h | 15h |

Figure 11. Read Identification (RDID) Instruction Sequence and Data-Out Sequence

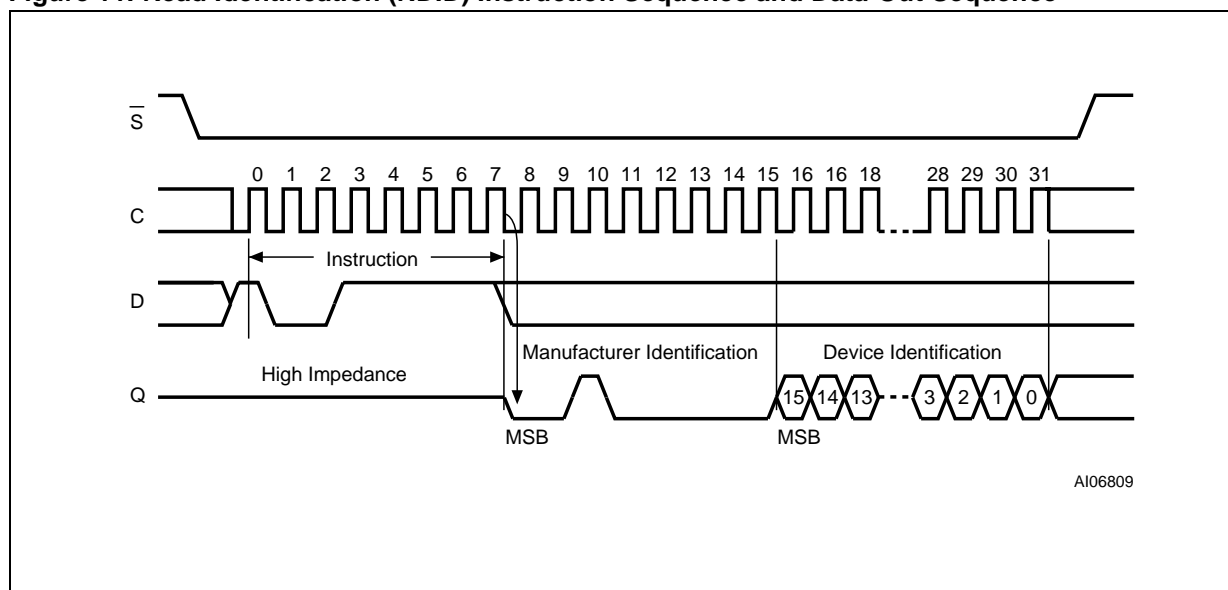

Read Status Register (RDSR)

The Read Status Register (RDSR) instruction allows the Status Register to be read. The Status Register may be read at any time, even while a Program, Erase or Write Status Register cycle is in progress. When one of these cycles is in progress, it is recommended to check the Write In Progress (WIP) bit before sending a new instruction to the device. It is also possible to read the Status Register continuously, as shown in Figure 12..

Table 6. Status Register Format

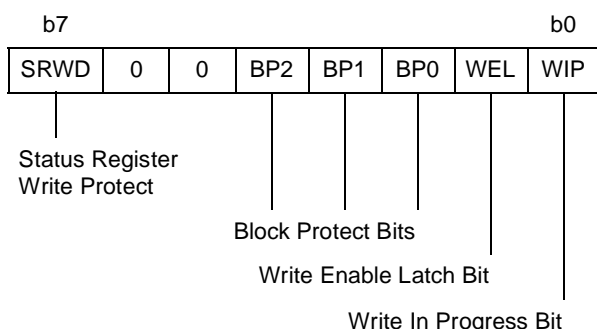

The status and control bits of the Status Register are as follows:

WIP bit. The Write In Progress (WIP) bit indicates whether the memory is busy with a Write Status Register, Program or Erase cycle. When set to 1, such a cycle is in progress, when reset to 0 no such cycle is in progress.

WEL bit. The Write Enable Latch (WEL) bit indicates the status of the internal Write Enable Latch. When set to 1 the internal Write Enable Latch is set, when set to 0 the internal Write Enable Latch is reset and no Write Status Register, Program or Erase instruction is accepted.

BP2, BP1, BP0 bits. The Block Protect (BP2, BP1, BP0) bits are non-volatile. They define the size of the area to be software protected against Program and Erase instructions. These bits are written with the Write Status Register (WRSR) instruction. When one or both of the Block Protect (BP2, BP1, BP0) bits is set to 1, the relevant memory area (as defined in Table 2.) becomes protected against Page Program (PP) and Sector Erase (SE) instructions. The Block Protect (BP2, BP1, BP0) bits can be written provided that the Hardware Protected mode has not been set. The Bulk Erase (BE) instruction is executed if, and only if, both Block Protect (BP2, BP1, BP0) bits are 0.

SRWD bit. The Status Register Write Disable (SRWD) bit is operated in conjunction with the Write Protect (\bar{W}) signal. The Status Register Write Disable (SRWD) bit and Write Protect (\bar{W}) signal allow the device to be put in the Hardware Protected mode (when the Status Register Write Disable (SRWD) bit is set to 1, and Write Protect (\bar{W}) is driven Low). In this mode, the non-volatile bits of the Status Register (SRWD, BP2, BP1, BP0) become read-only bits and the Write Status Register (WRSR) instruction is no longer accepted for execution.

Figure 12. Read Status Register (RDSR) Instruction Sequence and Data-Out Sequence

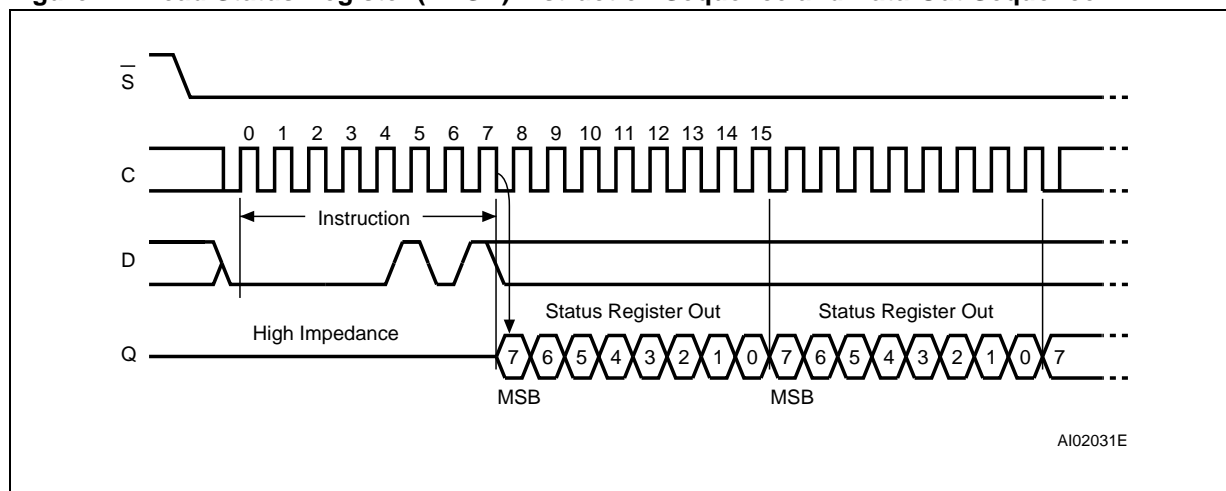

Write Status Register (WRSR)

The Write Status Register (WRSR) instruction allows new values to be written to the Status Register. Before it can be accepted, a Write Enable (WREN) instruction must previously have been executed. After the Write Enable (WREN) instruction has been decoded and executed, the device sets the Write Enable Latch (WEL).

The Write Status Register (WRSR) instruction is entered by driving Chip Select (\bar{S}) Low, followed by the instruction code and the data byte on Serial Data Input (D).

The instruction sequence is shown in Figure 13..

The Write Status Register (WRSR) instruction has no effect on b6, b5, b1 and b0 of the Status Register. b6 and b5 are always read as 0.

Chip Select (\bar{S}) must be driven High after the eighth bit of the data byte has been latched in. If not, the Write Status Register (WRSR) instruction is not executed. As soon as Chip Select (\bar{S}) is driven High, the self-timed Write Status Register cycle

(whose duration is t_{W}) is initiated. While the Write Status Register cycle is in progress, the Status Register may still be read to check the value of the Write In Progress (WIP) bit. The Write In Progress (WIP) bit is 1 during the self-timed Write Status Register cycle, and is 0 when it is completed. When the cycle is completed, the Write Enable Latch (WEL) is reset.

The Write Status Register (WRSR) instruction allows the user to change the values of the Block Protect (BP2, BP1, BP0) bits, to define the size of the area that is to be treated as read-only, as defined in Table 2.. The Write Status Register (WRSR) instruction also allows the user to set or reset the Status Register Write Disable (SRWD) bit in accordance with the Write Protect (\bar{W}) signal. The Status Register Write Disable (SRWD) bit and Write Protect (\bar{W}) signal allow the device to be put in the Hardware Protected Mode (HPM). The Write Status Register (WRSR) instruction is not executed once the Hardware Protected Mode (HPM) is entered.

Figure 13. Write Status Register (WRSR) Instruction Sequence

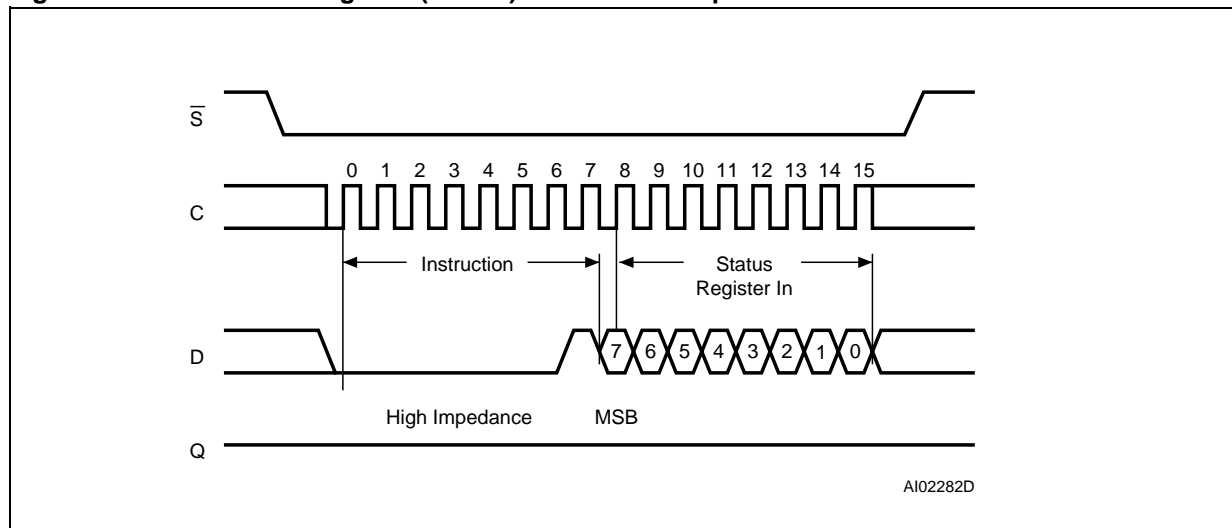

Table 7. Protection Modes

| \overline{W} Signal | SRWD Bit | Mode | Write Protection of the Status Register | Memory Content | |
|-----------------------|----------|--------------------------|---|---|--|
| | | | | Protected Area ¹ | Unprotected Area ¹ |
| 1 | 0 | Software Protected (SPM) | Status Register is Writable (if the WREN instruction has set the WEL bit) The values in the SRWD, BP2, BP1 and BP0 bits can be changed | Protected against Page Program, Sector Erase and Bulk Erase | Ready to accept Page Program and Sector Erase instructions |
| 0 | 0 | | | | |
| 1 | 1 | | | | |
| 0 | 1 | Hardware Protected (HPM) | Status Register is Hardware write protected The values in the SRWD, BP2, BP1 and BP0 bits cannot be changed | Protected against Page Program, Sector Erase and Bulk Erase | Ready to accept Page Program and Sector Erase instructions |

Note: 1. As defined by the values in the Block Protect (BP2, BP1, BP0) bits of the Status Register, as shown in Table 2.

The protection features of the device are summarized in Table 7..

When the Status Register Write Disable (SRWD) bit of the Status Register is 0 (its initial delivery state), it is possible to write to the Status Register provided that the Write Enable Latch (WEL) bit has previously been set by a Write Enable (WREN) instruction, regardless of the whether Write Protect (\overline{W}) is driven High or Low.

When the Status Register Write Disable (SRWD) bit of the Status Register is set to 1, two cases need to be considered, depending on the state of Write Protect (\overline{W}):

- If Write Protect (\overline{W}) is driven High, it is possible to write to the Status Register provided that the Write Enable Latch (WEL) bit has previously been set by a Write Enable (WREN) instruction.
- If Write Protect (\overline{W}) is driven Low, it is *not* possible to write to the Status Register *even* if the Write Enable Latch (WEL) bit has previously been set by a Write Enable (WREN) instruction. (Attempts to write to the

Status Register are rejected, and are not accepted for execution). As a consequence, all the data bytes in the memory area that are software protected (SPM) by the Block Protect (BP2, BP1, BP0) bits of the Status Register, are also hardware protected against data modification.

Regardless of the order of the two events, the Hardware Protected Mode (HPM) can be entered:

- by setting the Status Register Write Disable (SRWD) bit after driving Write Protect (\overline{W}) Low
- or by driving Write Protect (\overline{W}) Low after setting the Status Register Write Disable (SRWD) bit.

The only way to exit the Hardware Protected Mode (HPM) once entered is to pull Write Protect (\overline{W}) High.

If Write Protect (\overline{W}) is permanently tied High, the Hardware Protected Mode (HPM) can never be activated, and only the Software Protected Mode (SPM), using the Block Protect (BP2, BP1, BP0) bits of the Status Register, can be used.

Read Data Bytes (READ)

The device is first selected by driving Chip Select (\overline{S}) Low. The instruction code for the Read Data Bytes (READ) instruction is followed by a 3-byte address (A23-A0), each bit being latched-in during the rising edge of Serial Clock (C). Then the memory contents, at that address, is shifted out on Serial Data Output (Q), each bit being shifted out, at a maximum frequency f_R , during the falling edge of Serial Clock (C).

The instruction sequence is shown in Figure 14..

The first byte addressed can be at any location. The address is automatically incremented to the

next higher address after each byte of data is shifted out. The whole memory can, therefore, be read with a single Read Data Bytes (READ) instruction. When the highest address is reached, the address counter rolls over to 000000h, allowing the read sequence to be continued indefinitely.

The Read Data Bytes (READ) instruction is terminated by driving Chip Select (\overline{S}) High. Chip Select (\overline{S}) can be driven High at any time during data output. Any Read Data Bytes (READ) instruction, while an Erase, Program or Write cycle is in progress, is rejected without having any effects on the cycle that is in progress.

Figure 14. Read Data Bytes (READ) Instruction Sequence and Data-Out Sequence

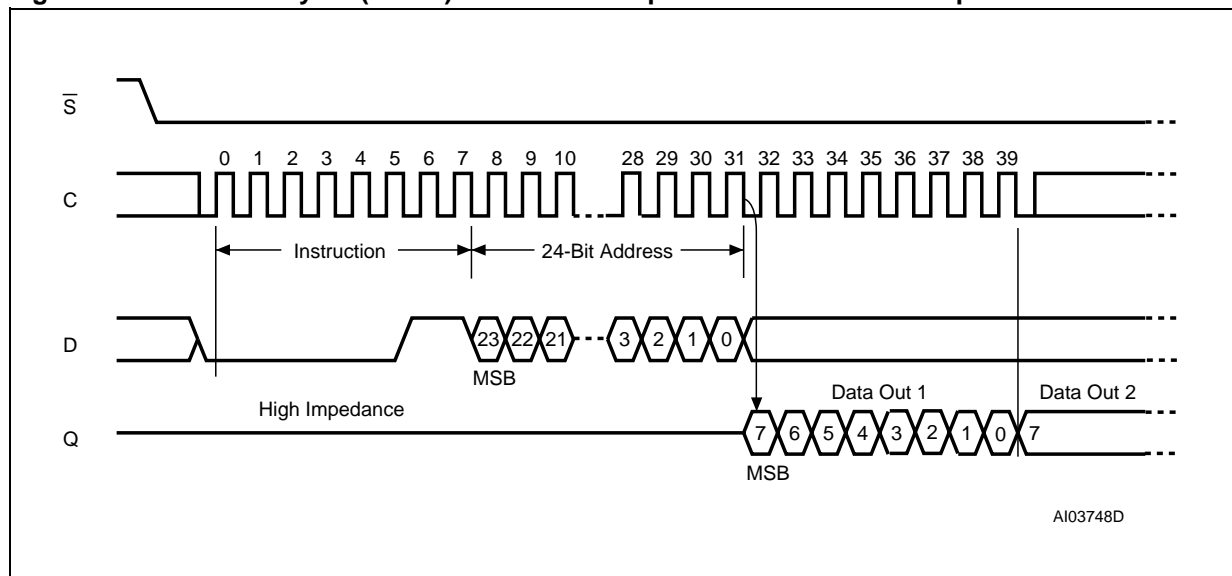

Note: Address bits A23 to A21 are Don't Care.

Read Data Bytes at Higher Speed (FAST_READ)

The device is first selected by driving Chip Select (\bar{S}) Low. The instruction code for the Read Data Bytes at Higher Speed (FAST_READ) instruction is followed by a 3-byte address (A23-A0) and a dummy byte, each bit being latched-in during the rising edge of Serial Clock (C). Then the memory contents, at that address, is shifted out on Serial Data Output (Q), each bit being shifted out, at a maximum frequency f_C , during the falling edge of Serial Clock (C).

The instruction sequence is shown in Figure 15.. The first byte addressed can be at any location. The address is automatically incremented to the

next higher address after each byte of data is shifted out. The whole memory can, therefore, be read with a single Read Data Bytes at Higher Speed (FAST_READ) instruction. When the highest address is reached, the address counter rolls over to 000000h, allowing the read sequence to be continued indefinitely.

The Read Data Bytes at Higher Speed (FAST_READ) instruction is terminated by driving Chip Select (\bar{S}) High. Chip Select (\bar{S}) can be driven High at any time during data output. Any Read Data Bytes at Higher Speed (FAST_READ) instruction, while an Erase, Program or Write cycle is in progress, is rejected without having any effects on the cycle that is in progress.

Figure 15. Read Data Bytes at Higher Speed (FAST_READ) Instruction Sequence and Data-Out Sequence

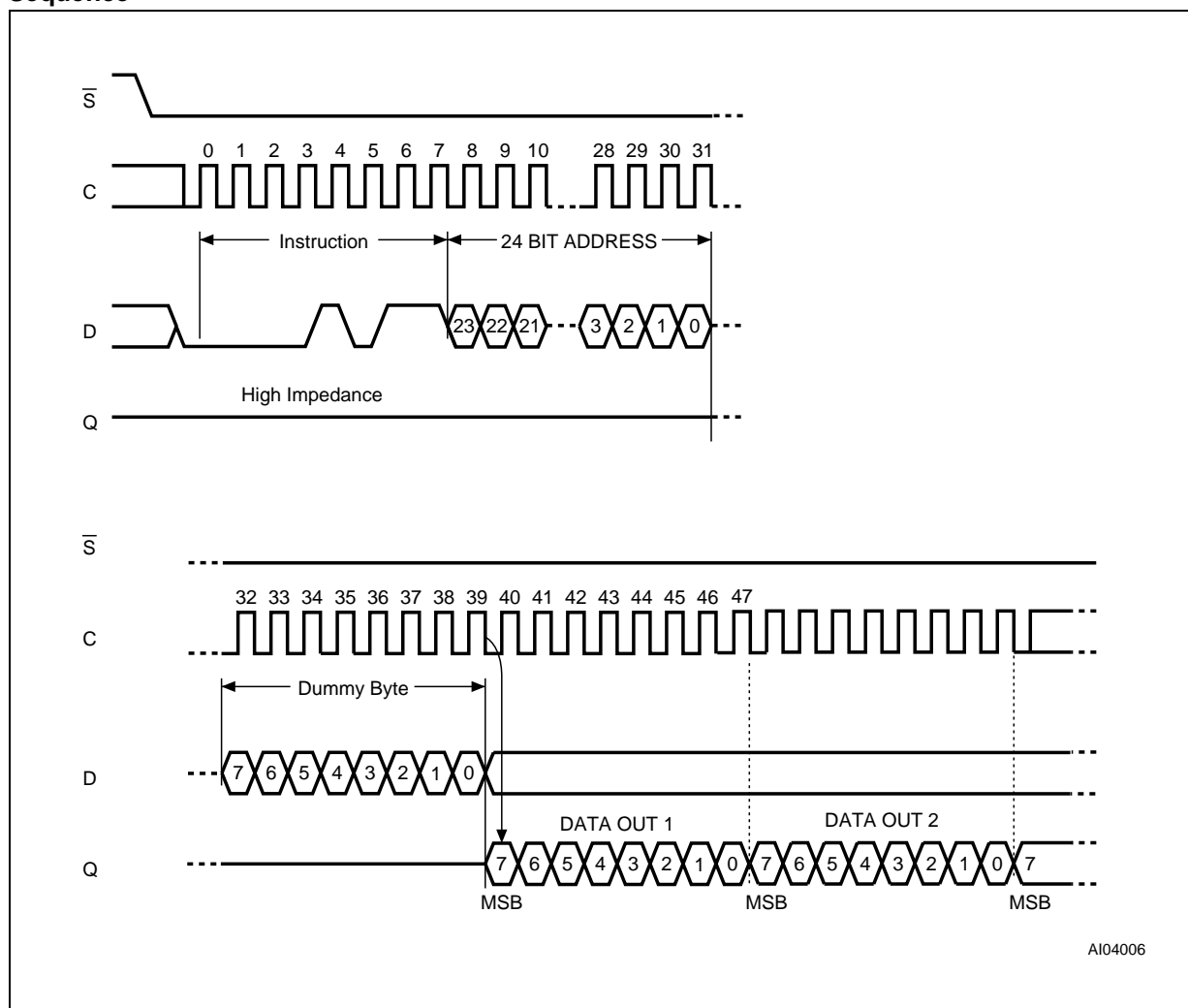

Note: 1. Address bits A23 to A21 are Don't Care.

Page Program (PP)

The Page Program (PP) instruction allows bytes to be programmed in the memory (changing bits from 1 to 0). Before it can be accepted, a Write Enable (WREN) instruction must previously have been executed. After the Write Enable (WREN) instruction has been decoded, the device sets the Write Enable Latch (WEL).

The Page Program (PP) instruction is entered by driving Chip Select (\bar{S}) Low, followed by the instruction code, three address bytes and at least one data byte on Serial Data Input (D). If the 8 least significant address bits (A7-A0) are not all zero, all transmitted data that goes beyond the end of the current page are programmed from the start address of the same page (from the address whose 8 least significant bits (A7-A0) are all zero). Chip Select (\bar{S}) must be driven Low for the entire duration of the sequence.

The instruction sequence is shown in Figure 16.

If more than 256 bytes are sent to the device, previously latched data are discarded and the last 256 data bytes are guaranteed to be programmed cor-

rectly within the same page. If less than 256 Data bytes are sent to device, they are correctly programmed at the requested addresses without having any effects on the other bytes of the same page.

Chip Select (\bar{S}) must be driven High after the eighth bit of the last data byte has been latched in, otherwise the Page Program (PP) instruction is not executed.

As soon as Chip Select (\bar{S}) is driven High, the self-timed Page Program cycle (whose duration is t_{PP}) is initiated. While the Page Program cycle is in progress, the Status Register may be read to check the value of the Write In Progress (WIP) bit. The Write In Progress (WIP) bit is 1 during the self-timed Page Program cycle, and is 0 when it is completed. At some unspecified time before the cycle is completed, the Write Enable Latch (WEL) bit is reset.

A Page Program (PP) instruction applied to a page which is protected by the Block Protect (BP2, BP1, BP0) bits (see Table 2. and Table 3.) is not executed.

Figure 16. Page Program (PP) Instruction Sequence

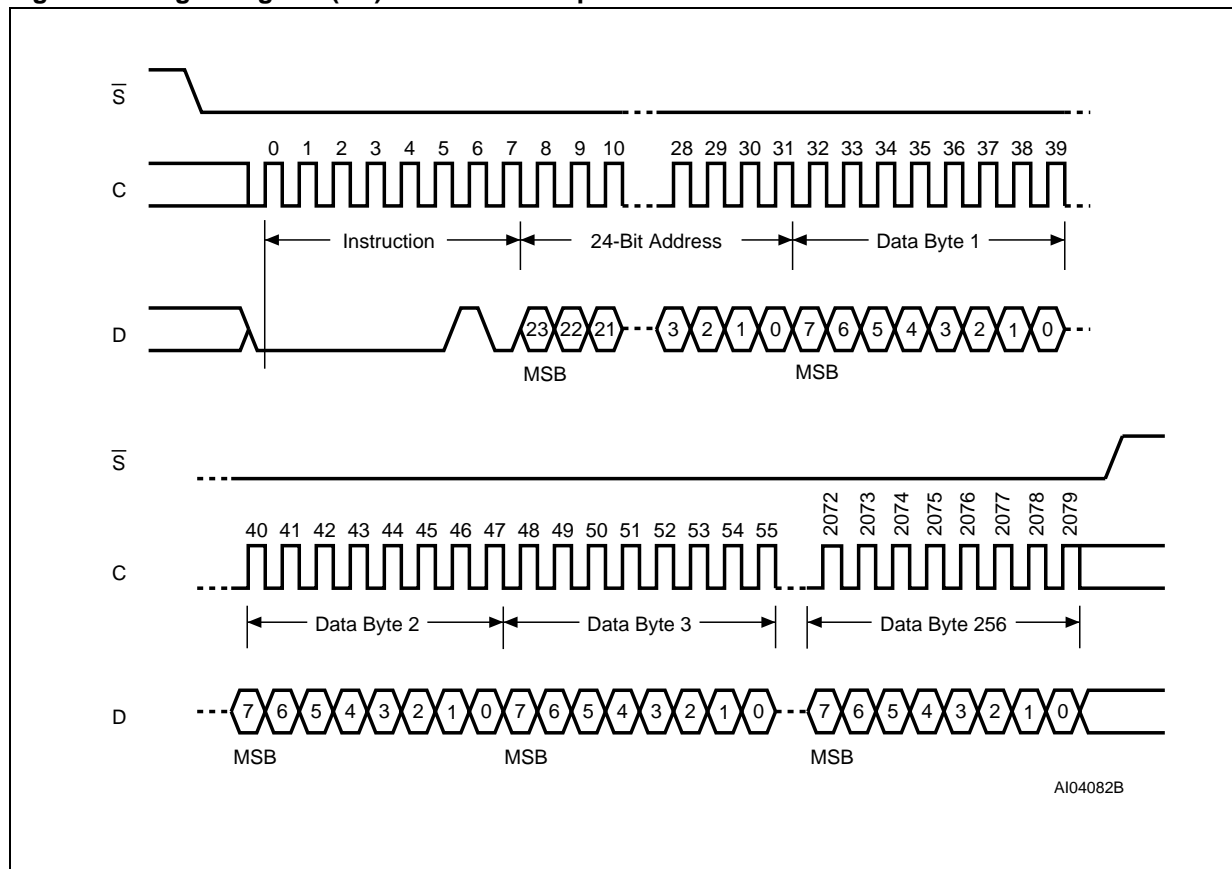

Note: Address bits A23 to A21 are Don't Care.

Sector Erase (SE)

The Sector Erase (SE) instruction sets to 1 (FFh) all bits inside the chosen sector. Before it can be accepted, a Write Enable (WREN) instruction must previously have been executed. After the Write Enable (WREN) instruction has been decoded, the device sets the Write Enable Latch (WEL).

The Sector Erase (SE) instruction is entered by driving Chip Select (\bar{S}) Low, followed by the instruction code, and three address bytes on Serial Data Input (D). Any address inside the Sector (see Table 3.) is a valid address for the Sector Erase (SE) instruction. Chip Select (\bar{S}) must be driven Low for the entire duration of the sequence.

The instruction sequence is shown in Figure 17..

Chip Select (\bar{S}) must be driven High after the eighth bit of the last address byte has been latched in, otherwise the Sector Erase (SE) instruction is not executed. As soon as Chip Select (\bar{S}) is driven High, the self-timed Sector Erase cycle (whose duration is t_{SE}) is initiated. While the Sector Erase cycle is in progress, the Status Register may be read to check the value of the Write In Progress (WIP) bit. The Write In Progress (WIP) bit is 1 during the self-timed Sector Erase cycle, and is 0 when it is completed. At some unspecified time before the cycle is completed, the Write Enable Latch (WEL) bit is reset.

A Sector Erase (SE) instruction applied to a page which is protected by the Block Protect (BP2, BP1, BP0) bits (see Table 2. and Table 3.) is not executed.

Figure 17. Sector Erase (SE) Instruction Sequence

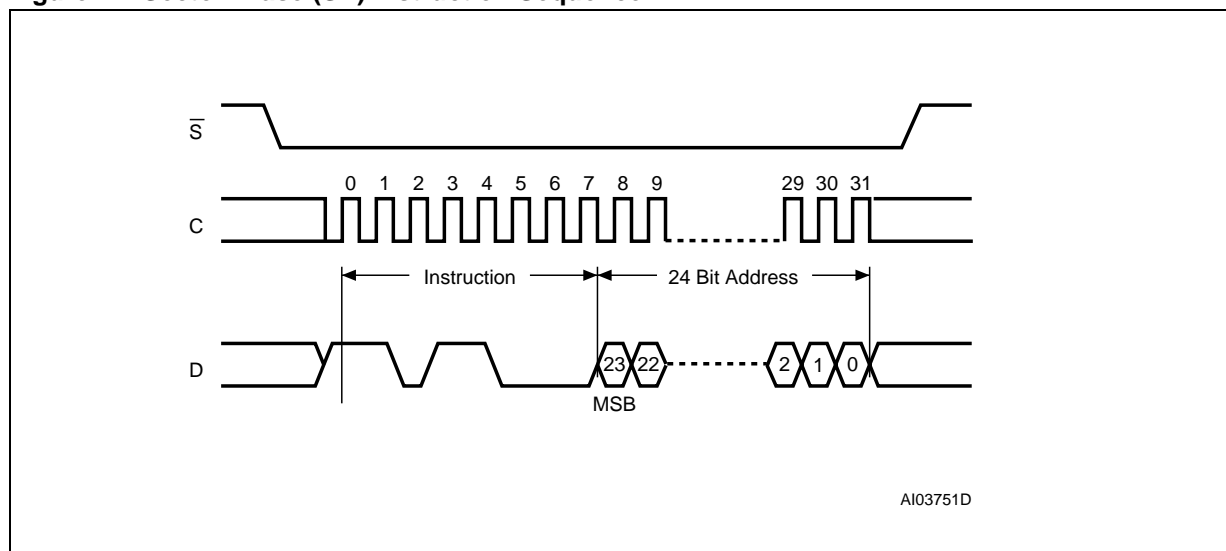

Note: Address bits A23 to A21 are Don't Care.

Bulk Erase (BE)

The Bulk Erase (BE) instruction sets all bits to 1 (FFh). Before it can be accepted, a Write Enable (WREN) instruction must previously have been executed. After the Write Enable (WREN) instruction has been decoded, the device sets the Write Enable Latch (WEL).

The Bulk Erase (BE) instruction is entered by driving Chip Select (\bar{S}) Low, followed by the instruction code on Serial Data Input (D). Chip Select (\bar{S}) must be driven Low for the entire duration of the sequence.

The instruction sequence is shown in Figure 18..

Chip Select (\bar{S}) must be driven High after the eighth bit of the instruction code has been latched

in, otherwise the Bulk Erase instruction is not executed. As soon as Chip Select (\bar{S}) is driven High, the self-timed Bulk Erase cycle (whose duration is t_{BE}) is initiated. While the Bulk Erase cycle is in progress, the Status Register may be read to check the value of the Write In Progress (WIP) bit. The Write In Progress (WIP) bit is 1 during the self-timed Bulk Erase cycle, and is 0 when it is completed. At some unspecified time before the cycle is completed, the Write Enable Latch (WEL) bit is reset.

The Bulk Erase (BE) instruction is executed only if all Block Protect (BP2, BP1, BP0) bits are 0. The Bulk Erase (BE) instruction is ignored if one, or more, sectors are protected.

Figure 18. Bulk Erase (BE) Instruction Sequence

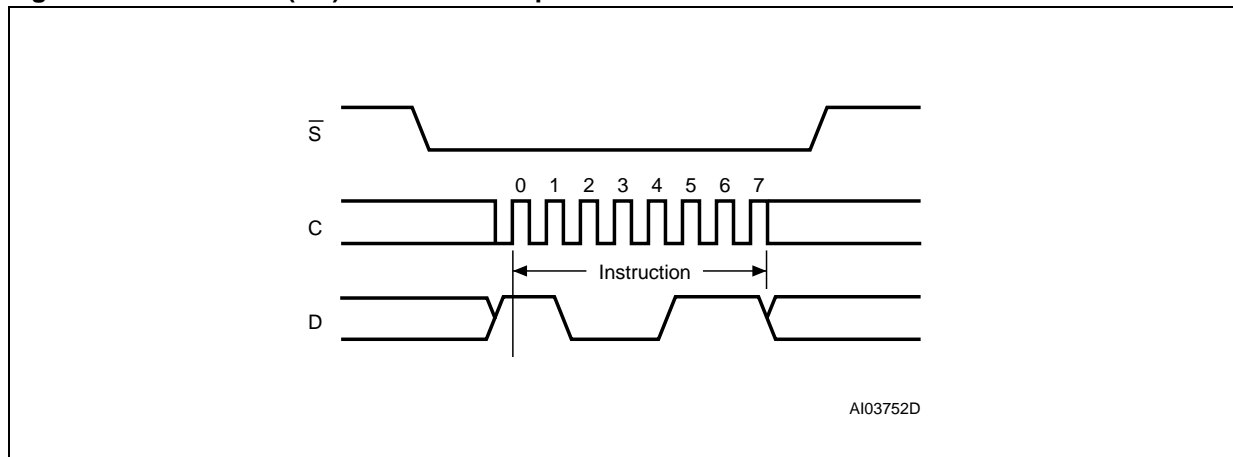

Deep Power-down (DP)

Executing the Deep Power-down (DP) instruction is the only way to put the device in the lowest consumption mode (the Deep Power-down mode). It can also be used as an extra software protection mechanism, while the device is not in active use, since in this mode, the device ignores all Write, Program and Erase instructions.

Driving Chip Select (\bar{S}) High deselects the device, and puts the device in the Standby mode (if there is no internal cycle currently in progress). But this mode is not the Deep Power-down mode. The Deep Power-down mode can only be entered by executing the Deep Power-down (DP) instruction, to reduce the standby current (from I_{CC1} to I_{CC2} , as specified in Table 13.).

Once the device has entered the Deep Power-down mode, all instructions are ignored except the Release from Deep Power-down and Read Electronic Signature (RES) instruction. This releases the device from this mode. The Release from Deep Power-down and Read Electronic Signature (RES) instruction also allows the Electronic Signa-

ture of the device to be output on Serial Data Output (Q).

The Deep Power-down mode automatically stops at Power-down, and the device always Powers-up in the Standby mode.

The Deep Power-down (DP) instruction is entered by driving Chip Select (\bar{S}) Low, followed by the instruction code on Serial Data Input (D). Chip Select (\bar{S}) must be driven Low for the entire duration of the sequence.

The instruction sequence is shown in Figure 19..

Chip Select (\bar{S}) must be driven High after the eighth bit of the instruction code has been latched in, otherwise the Deep Power-down (DP) instruction is not executed. As soon as Chip Select (\bar{S}) is driven High, it requires a delay of t_{DP} before the supply current is reduced to I_{CC2} and the Deep Power-down mode is entered.

Any Deep Power-down (DP) instruction, while an Erase, Program or Write cycle is in progress, is rejected without having any effects on the cycle that is in progress.

Figure 19. Deep Power-down (DP) Instruction Sequence

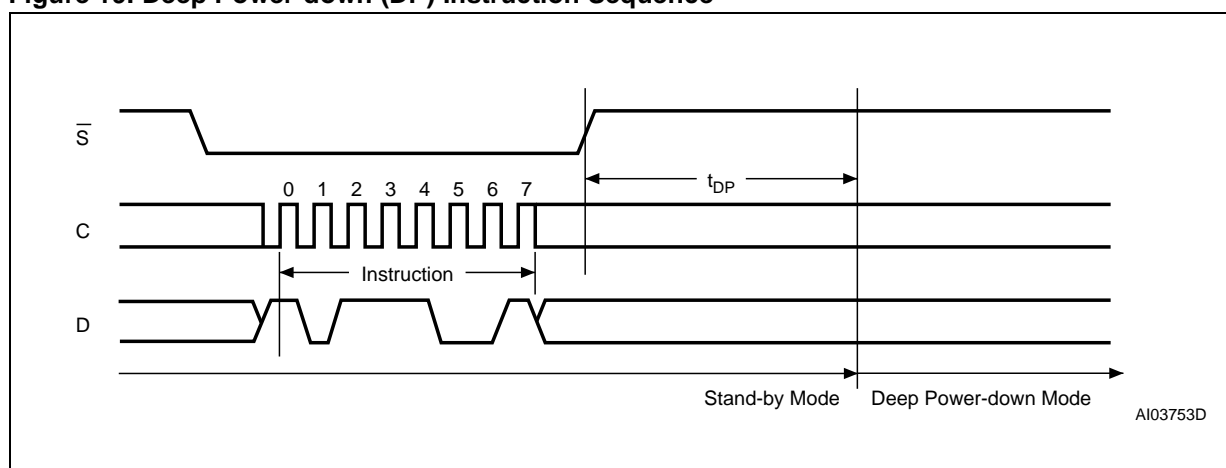

Release from Deep Power-down and Read Electronic Signature (RES)

Once the device has entered the Deep Power-down mode, all instructions are ignored except the Release from Deep Power-down and Read Electronic Signature (RES) instruction. Executing this instruction takes the device out of the Deep Power-down mode.

The instruction can also be used to read, on Serial Data Output (Q), the old-style 8-bit Electronic Signature, whose value for the M25P16 is 14h.

Please note that this is not the same as, or even a subset of, the JEDEC 16-bit Electronic Signature that is read by the Read Identifier (RDID) instruction. The old-style Electronic Signature is supported for reasons of backward compatibility, only, and should not be used for new designs. New designs should, instead, make use of the JEDEC 16-bit Electronic Signature, and the Read Identifier (RDID) instruction.

Except while an Erase, Program or Write Status Register cycle is in progress, the Release from Deep Power-down and Read Electronic Signature (RES) instruction always provides access to the old-style 8-bit Electronic Signature of the device, and can be applied even if the Deep Power-down mode has not been entered.

Any Release from Deep Power-down and Read Electronic Signature (RES) instruction while an Erase, Program or Write Status Register cycle is in

progress, is not decoded, and has no effect on the cycle that is in progress.

The device is first selected by driving Chip Select (\bar{S}) Low. The instruction code is followed by 3 dummy bytes, each bit being latched-in on Serial Data Input (D) during the rising edge of Serial Clock (C). Then, the old-style 8-bit Electronic Signature, stored in the memory, is shifted out on Serial Data Output (Q), each bit being shifted out during the falling edge of Serial Clock (C).

The instruction sequence is shown in Figure 20.

The Release from Deep Power-down and Read Electronic Signature (RES) instruction is terminated by driving Chip Select (\bar{S}) High after the Electronic Signature has been read at least once. Sending additional clock cycles on Serial Clock (C), while Chip Select (\bar{S}) is driven Low, cause the Electronic Signature to be output repeatedly.

When Chip Select (\bar{S}) is driven High, the device is put in the Stand-by Power mode. If the device was not previously in the Deep Power-down mode, the transition to the Stand-by Power mode is immediate. If the device was previously in the Deep Power-down mode, though, the transition to the Stand-by Power mode is delayed by t_{RES2} , and Chip Select (\bar{S}) must remain High for at least $t_{RES2(max)}$, as specified in Table 14. Once in the Stand-by Power mode, the device waits to be selected, so that it can receive, decode and execute instructions.

Figure 20. Release from Deep Power-down and Read Electronic Signature (RES) Instruction Sequence and Data-Out Sequence

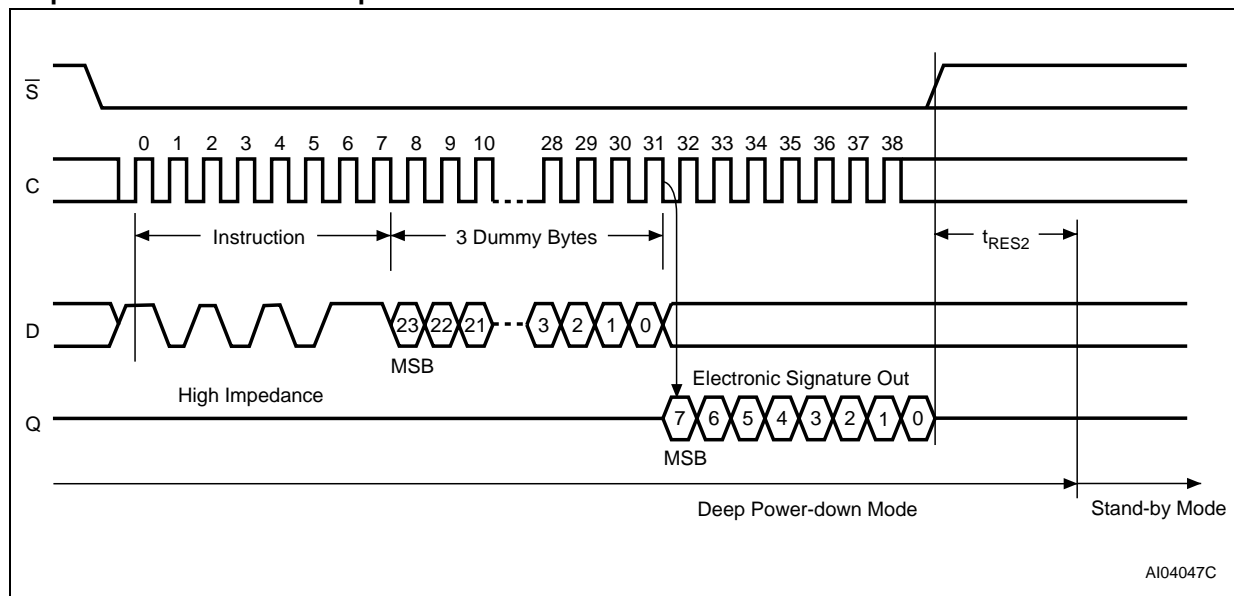

Note: The value of the 8-bit Electronic Signature, for the M25P16, is 14h.

Figure 21. Release from Deep Power-down (RES) Instruction Sequence

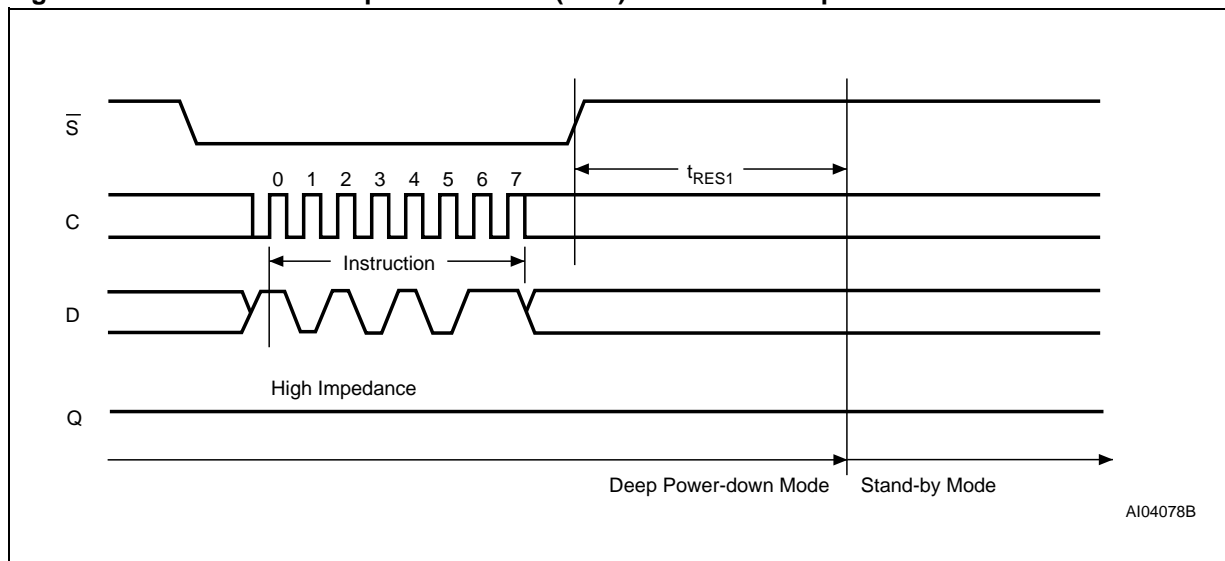

Driving Chip Select (\overline{CS}) High after the 8-bit instruction byte has been received by the device, but before the whole of the 8-bit Electronic Signature has been transmitted for the first time (as shown in [Figure 21.](#)), still insures that the device is put into Stand-by Power mode. If the device was not previously in the Deep Power-down mode, the transition to the Stand-by Power mode is immediate. If

the device was previously in the Deep Power-down mode, though, the transition to the Stand-by Power mode is delayed by t_{RES1} , and Chip Select (\overline{CS}) must remain High for at least $t_{RES1(max)}$, as specified in [Table 14.](#) Once in the Stand-by Power mode, the device waits to be selected, so that it can receive, decode and execute instructions.

POWER-UP AND POWER-DOWN

At Power-up and Power-down, the device must not be selected (that is Chip Select (\bar{S}) must follow the voltage applied on V_{CC}) until V_{CC} reaches the correct value:

- $V_{CC}(\text{min})$ at Power-up, and then for a further delay of t_{VSL}
- V_{SS} at Power-down

Usually a simple pull-up resistor on Chip Select (\bar{S}) can be used to insure safe and proper Power-up and Power-down.

To avoid data corruption and inadvertent write operations during power up, a Power On Reset (POR) circuit is included. The logic inside the device is held reset while V_{CC} is less than the POR threshold value, V_{WI} – all operations are disabled, and the device does not respond to any instruction.

Moreover, the device ignores all Write Enable (WREN), Page Program (PP), Sector Erase (SE), Bulk Erase (BE) and Write Status Register (WRSR) instructions until a time delay of t_{PUW} has elapsed after the moment that V_{CC} rises above the V_{WI} threshold. However, the correct operation of the device is not guaranteed if, by this time, V_{CC} is still below $V_{CC}(\text{min})$. No Write Status Register,

Program or Erase instructions should be sent until the later of:

- t_{PUW} after V_{CC} passed the V_{WI} threshold
- t_{VSL} after V_{CC} passed the $V_{CC}(\text{min})$ level

These values are specified in Table 8.

If the delay, t_{VSL} , has elapsed, after V_{CC} has risen above $V_{CC}(\text{min})$, the device can be selected for READ instructions even if the t_{PUW} delay is not yet fully elapsed.

At Power-up, the device is in the following state:

- The device is in the Standby mode (not the Deep Power-down mode).
- The Write Enable Latch (WEL) bit is reset.

Normal precautions must be taken for supply rail decoupling, to stabilize the V_{CC} feed. Each device in a system should have the V_{CC} rail decoupled by a suitable capacitor close to the package pins. (Generally, this capacitor is of the order of 0.1 μF).

At Power-down, when V_{CC} drops from the operating voltage, to below the POR threshold value, V_{WI} , all operations are disabled and the device does not respond to any instruction. (The designer needs to be aware that if a Power-down occurs while a Write, Program or Erase cycle is in progress, some data corruption can result.)

Figure 22. Power-up Timing

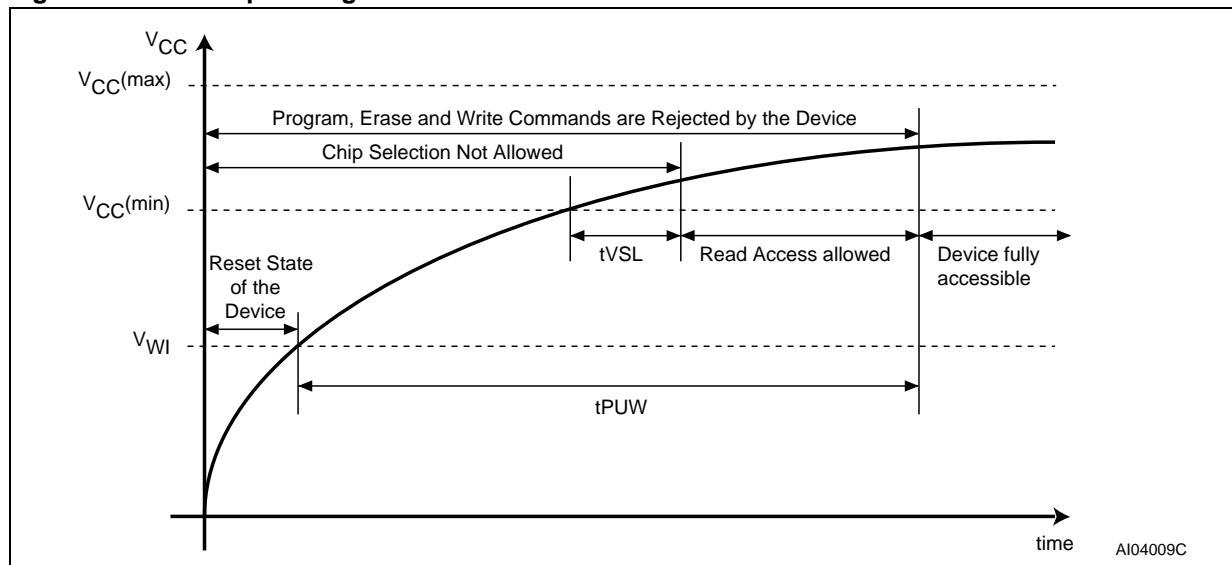

Table 8. Power-Up Timing and V_{WI} Threshold

| Symbol | Parameter | Min. | Max. | Unit |
|-------------|---------------------------------------|------|------|---------------|
| t_{VSL}^1 | $V_{CC}(\text{min})$ to \bar{S} Low | 30 | | μs |
| t_{PUW}^1 | Time delay to Write instruction | 1 | 10 | ms |
| V_{WI}^1 | Write Inhibit Voltage | 1.5 | 2.5 | V |

Note: 1. These parameters are characterized only.

INITIAL DELIVERY STATE

The device is delivered with the memory array erased: all bits are set to 1 (each byte contains

FFh). The Status Register contains 00h (all Status Register bits are 0).

MAXIMUM RATING

Stressing the device above the rating listed in the "Absolute Maximum Ratings" table may cause permanent damage to the device. These are stress ratings only and operation of the device at these or any other conditions above those indicated in the Operating sections of this specification is not im-

plied. Exposure to Absolute Maximum Rating conditions for extended periods may affect device reliability. Refer also to the STMicroelectronics SURE Program and other relevant quality documents.

Table 9. Absolute Maximum Ratings

| Symbol | Parameter | Min. | Max. | Unit |
|-------------------|---|-----------------------|------|------|
| T _{STG} | Storage Temperature | -65 | 150 | °C |
| T _{LEAD} | Lead Temperature during Soldering | See note ¹ | | °C |
| V _{IO} | Input and Output Voltage (with respect to Ground) | -0.6 | 4.0 | V |
| V _{CC} | Supply Voltage | -0.6 | 4.0 | V |
| V _{ESD} | Electrostatic Discharge Voltage (Human Body model) ² | -2000 | 2000 | V |

Note: 1. Compliant with JEDEC Std J-STD-020B (for small body, Sn-Pb or Pb assembly), the ST ECOPACK[®] 7191395 specification, and the European directive on Restrictions on Hazardous Substances (RoHS) 2002/95/EU

2. JEDEC Std JESD22-A114A (C1=100 pF, R1=1500 Ω, R2=500 Ω)

DC AND AC PARAMETERS

This section summarizes the operating and measurement conditions, and the DC and AC characteristics of the device. The parameters in the DC and AC Characteristic tables that follow are derived from tests performed under the Measure-

ment Conditions summarized in the relevant tables. Designers should check that the operating conditions in their circuit match the measurement conditions when relying on the quoted parameters.

Table 10. Operating Conditions.

| Symbol | Parameter | Min. | Max. | Unit |
|-----------------|-------------------------------|------|------|------|
| V _{CC} | Supply Voltage | 2.7 | 3.6 | V |
| T _A | Ambient Operating Temperature | -40 | 85 | °C |

Table 11. AC Measurement Conditions

| Symbol | Parameter | Min. | Max. | Unit |
|----------------|----------------------------------|--|------|------|
| C _L | Load Capacitance | 30 | | pF |
| | Input Rise and Fall Times | | 5 | ns |
| | Input Pulse Voltages | 0.2V _{CC} to 0.8V _{CC} | | V |
| | Input Timing Reference Voltages | 0.3V _{CC} to 0.7V _{CC} | | V |
| | Output Timing Reference Voltages | V _{CC} / 2 | | V |

Note: Output Hi-Z is defined as the point where data out is no longer driven.

Figure 23. AC Measurement I/O Waveform

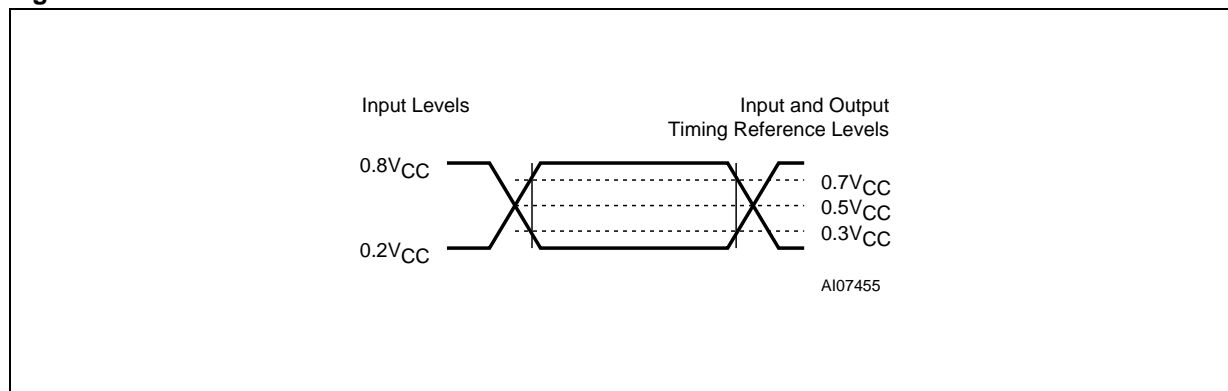

Table 12. Capacitance

| Symbol | Parameter | Test Condition | Min. | Max. | Unit |
|------------------|--------------------------------|-----------------------|------|------|------|
| C _{OUT} | Output Capacitance (Q) | V _{OUT} = 0V | | 8 | pF |
| C _{IN} | Input Capacitance (other pins) | V _{IN} = 0V | | 6 | pF |

Note: Sampled only, not 100% tested, at T_A=25°C and a frequency of 20 MHz.

Table 13. DC Characteristics

| Symbol | Parameter | Test Condition (in addition to those in Table 10.) | Min. | Max. | Unit |
|-----------|--------------------------|--|--------------|--------------|---------|
| I_{LI} | Input Leakage Current | | | ± 2 | μA |
| I_{LO} | Output Leakage Current | | | ± 2 | μA |
| I_{CC1} | Standby Current | $\bar{S} = V_{CC}, V_{IN} = V_{SS} \text{ or } V_{CC}$ | | 50 | μA |
| I_{CC2} | Deep Power-down Current | $\bar{S} = V_{CC}, V_{IN} = V_{SS} \text{ or } V_{CC}$ | | 10 | μA |
| I_{CC3} | Operating Current (READ) | $C = 0.1V_{CC} / 0.9.V_{CC}$ at 50MHz, Q = open | | 8 | mA |
| | | $C = 0.1V_{CC} / 0.9.V_{CC}$ at 20MHz, Q = open | | 4 | mA |
| I_{CC4} | Operating Current (PP) | $\bar{S} = V_{CC}$ | | 15 | mA |
| I_{CC5} | Operating Current (WRSR) | $\bar{S} = V_{CC}$ | | 15 | mA |
| I_{CC6} | Operating Current (SE) | $\bar{S} = V_{CC}$ | | 15 | mA |
| I_{CC7} | Operating Current (BE) | $\bar{S} = V_{CC}$ | | 15 | mA |
| V_{IL} | Input Low Voltage | | -0.5 | $0.3V_{CC}$ | V |
| V_{IH} | Input High Voltage | | $0.7V_{CC}$ | $V_{CC}+0.4$ | V |
| V_{OL} | Output Low Voltage | $I_{OL} = 1.6mA$ | | 0.4 | V |
| V_{OH} | Output High Voltage | $I_{OH} = -100\mu A$ | $V_{CC}-0.2$ | | V |

Table 14. AC Characteristics

| Test conditions specified in Table 10. and Table 11. | | | | | | |
|--|-----------|---|------|------|------|------|
| Symbol | Alt. | Parameter | Min. | Typ. | Max. | Unit |
| f_C | f_C | Clock Frequency ¹ for the following instructions: FAST_READ, PP, SE, BE, DP, RES, WREN, WRDI, RDID, RDSR, WRSR | D.C. | | 50 | MHz |
| f_R | | Clock Frequency for READ instructions | D.C. | | 20 | MHz |
| t_{CH}^1 | t_{CLH} | Clock High Time | 9 | | | ns |
| t_{CL}^1 | t_{CLL} | Clock Low Time | 9 | | | ns |
| t_{CLCH}^2 | | Clock Rise Time ³ (peak to peak) | 0.1 | | | V/ns |
| t_{CHCL}^2 | | Clock Fall Time ³ (peak to peak) | 0.1 | | | V/ns |
| t_{SLCH} | t_{CSS} | \bar{S} Active Setup Time (relative to C) | 5 | | | ns |
| t_{CHSL} | | \bar{S} Not Active Hold Time (relative to C) | 5 | | | ns |
| t_{DVCH} | t_{DSU} | Data In Setup Time | 2 | | | ns |
| t_{CHDX} | t_{DH} | Data In Hold Time | 5 | | | ns |
| t_{CHSH} | | \bar{S} Active Hold Time (relative to C) | 5 | | | ns |
| t_{SHCH} | | \bar{S} Not Active Setup Time (relative to C) | 5 | | | ns |
| t_{SHSL} | t_{CSH} | \bar{S} Deselect Time | 100 | | | ns |

| Test conditions specified in Table 10. and Table 11. | | | | | | |
|--|------------------|--|------|------|------|------|
| Symbol | Alt. | Parameter | Min. | Typ. | Max. | Unit |
| t _{SHQZ} ² | t _{DIS} | Output Disable Time | | | 8 | ns |
| t _{CLQV} | t _v | Clock Low to Output Valid | | | 8 | ns |
| t _{CLQX} | t _{HO} | Output Hold Time | 0 | | | ns |
| t _{HLCH} | | $\overline{\text{HOLD}}$ Setup Time (relative to C) | 5 | | | ns |
| t _{CHHH} | | $\overline{\text{HOLD}}$ Hold Time (relative to C) | 5 | | | ns |
| t _{HHCH} | | HOLD Setup Time (relative to C) | 5 | | | ns |
| t _{CHHL} | | HOLD Hold Time (relative to C) | 5 | | | ns |
| t _{HHQX} ² | t _{LZ} | HOLD to Output Low-Z | | | 8 | ns |
| t _{HLQZ} ² | t _{HZ} | $\overline{\text{HOLD}}$ to Output High-Z | | | 8 | ns |
| t _{WHSL} ⁴ | | Write Protect Setup Time | 20 | | | ns |
| t _{SHWL} ⁴ | | Write Protect Hold Time | 100 | | | ns |
| t _{DP} ² | | $\overline{\text{S}}$ High to Deep Power-down Mode | | | 3 | μs |
| t _{RES1} ² | | $\overline{\text{S}}$ High to Standby Mode without Electronic Signature Read | | | 30 | μs |
| t _{RES2} ² | | $\overline{\text{S}}$ High to Standby Mode with Electronic Signature Read | | | 30 | μs |
| t _w | | Write Status Register Cycle Time | | 5 | 15 | ms |
| t _{PP} | | Page Program Cycle Time | | 1.4 | 5 | ms |
| t _{SE} | | Sector Erase Cycle Time | | 1 | 3 | s |
| t _{BE} | | Bulk Erase Cycle Time | | 17 | 40 | s |

Note: 1. t_{CH} + t_{CL} must be greater than or equal to 1/ f_c
2. Value guaranteed by characterization, not 100% tested in production.
3. Expressed as a slew-rate.
4. Only applicable as a constraint for a WRSR instruction when SRWD is set at 1.

Figure 24. Serial Input Timing

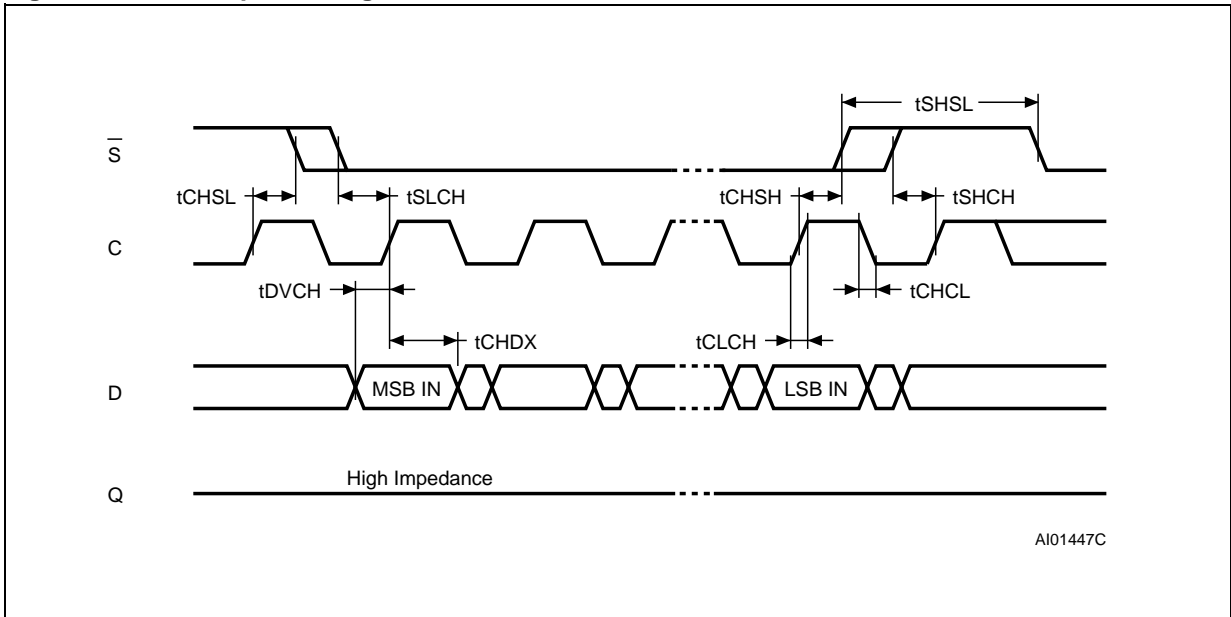

Figure 25. Write Protect Setup and Hold Timing during WRSR when SRWD=1

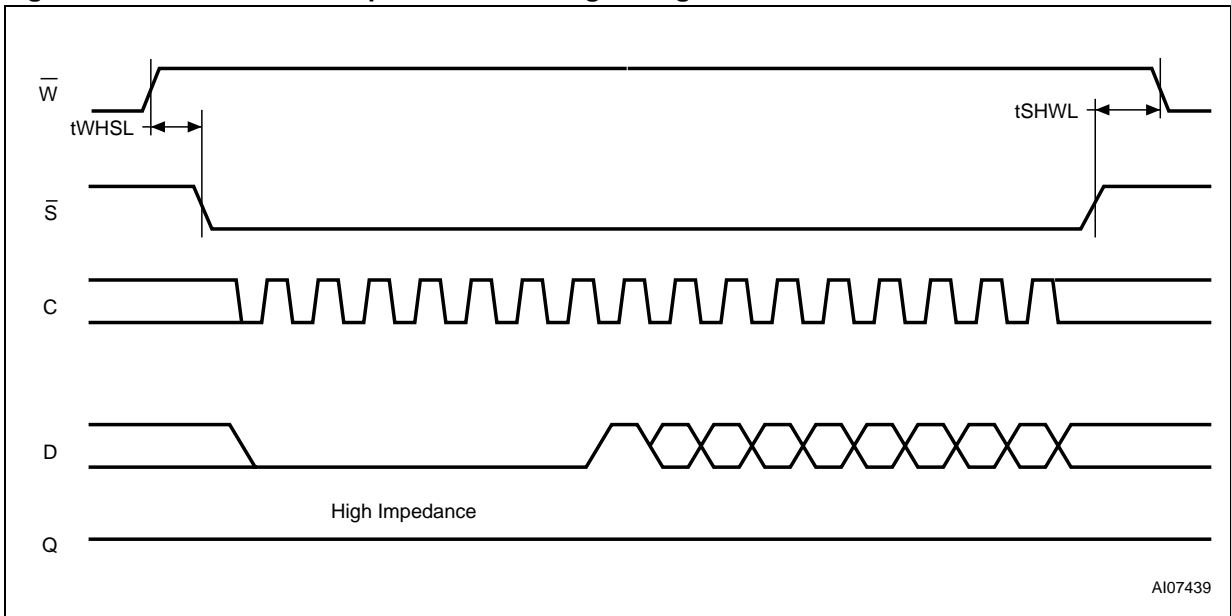

Figure 26. Hold Timing

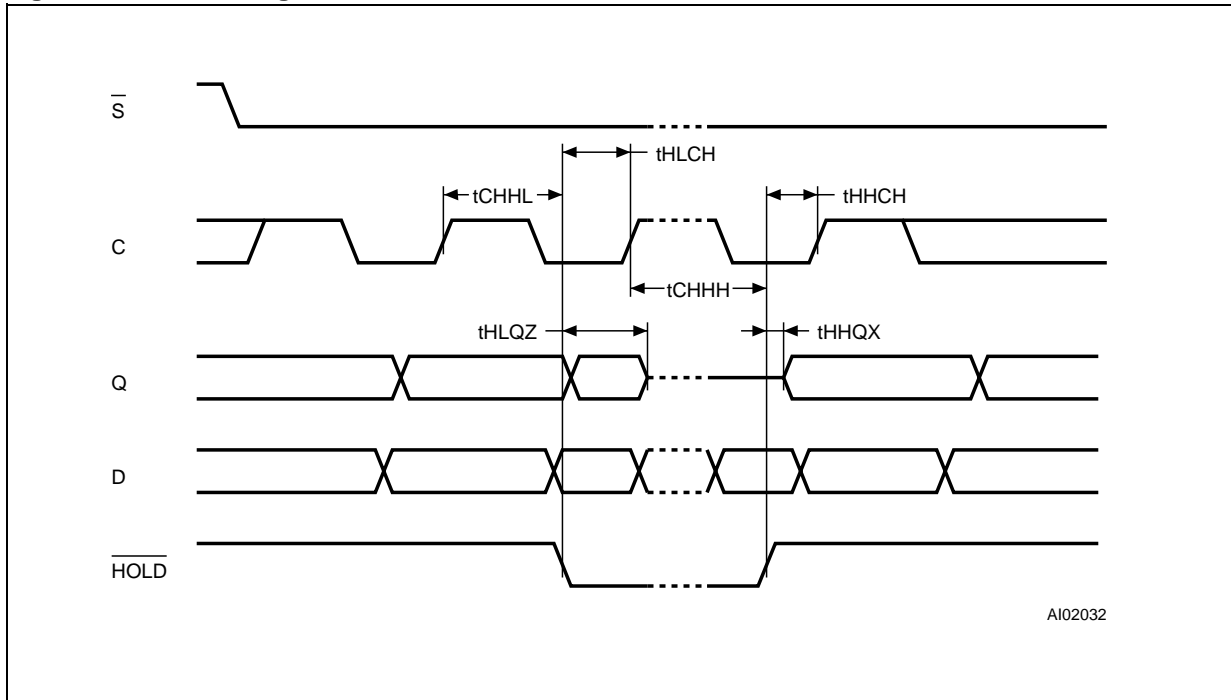
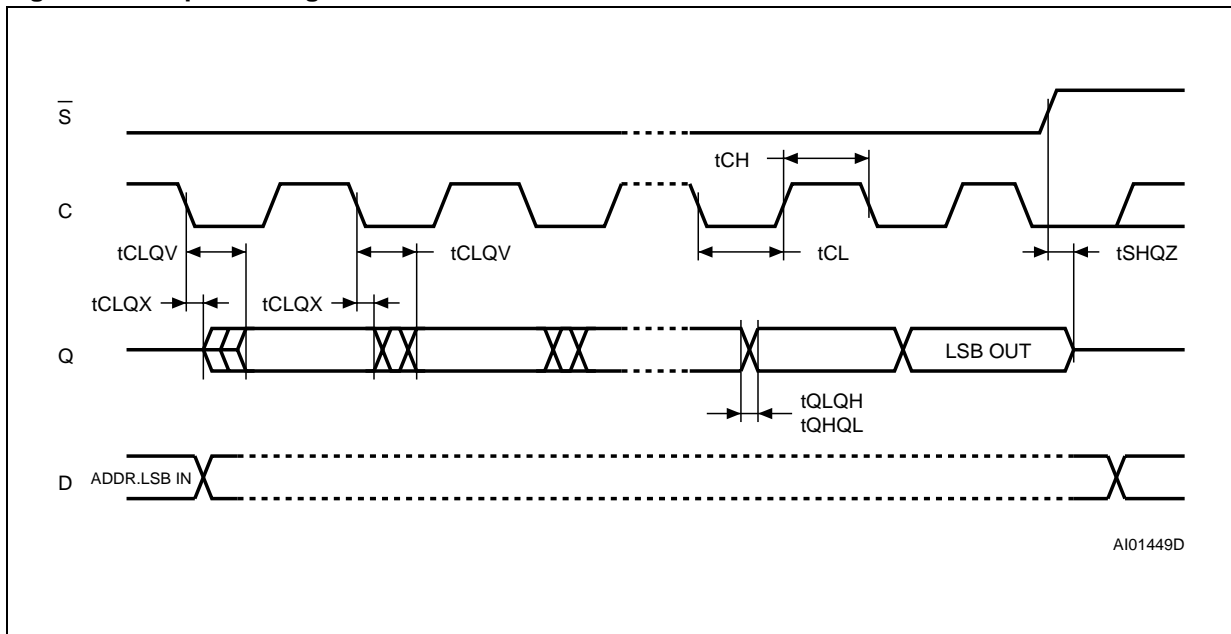
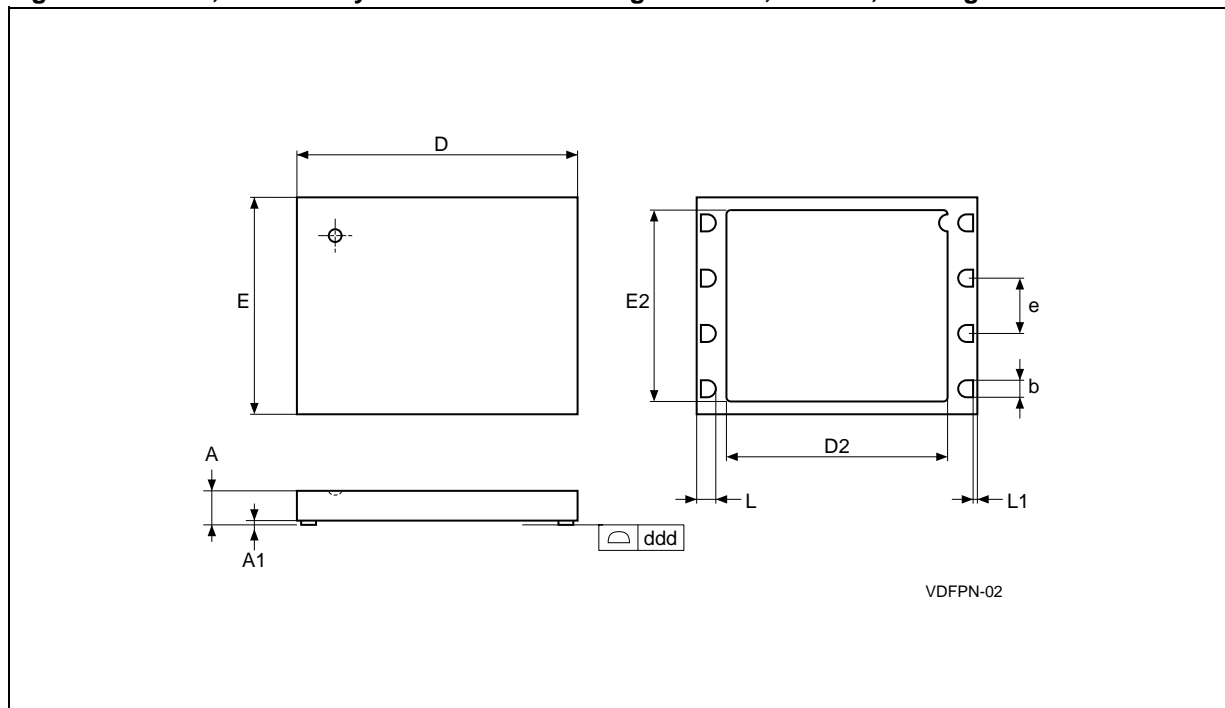

Figure 27. Output Timing



PACKAGE MECHANICAL

Figure 28. MLP8, 8-lead Very thin Dual Flat Package No lead, 8x6mm, Package Outline



Note: Drawing is not to scale.

Table 15. MLP8, 8-lead Very thin Dual Flat Package No lead, 8x6mm, Package Mechanical Data

| Symb. | mm | | | inches | | |
|-------|------|------|------|--------|--------|--------|
| | Typ. | Min. | Max. | Typ. | Min. | Max. |
| A | 0.85 | | 1.00 | 0.0335 | | 0.0394 |
| A1 | | 0.00 | 0.05 | | 0.0000 | 0.0020 |
| b | 0.40 | 0.35 | 0.48 | 0.0157 | 0.0138 | 0.0189 |
| D | 8.00 | | | 0.3150 | | |
| D2 | 6.40 | | | 0.2520 | | |
| ddd | | | 0.05 | | | 0.0020 |
| E | 6.00 | | | 0.2362 | | |
| E2 | 4.80 | | | 0.1890 | | |
| e | 1.27 | – | – | 0.0500 | – | – |
| K | | 0.20 | | | 0.0079 | |
| L | 0.50 | 0.45 | 0.60 | 0.0197 | 0.0177 | 0.0236 |
| L1 | | | 0.15 | | | 0.0059 |
| N | 8 | | | 8 | | |

Figure 29. SO16 wide – 16-lead Plastic Small Outline, 300 mils body width, Package Outline

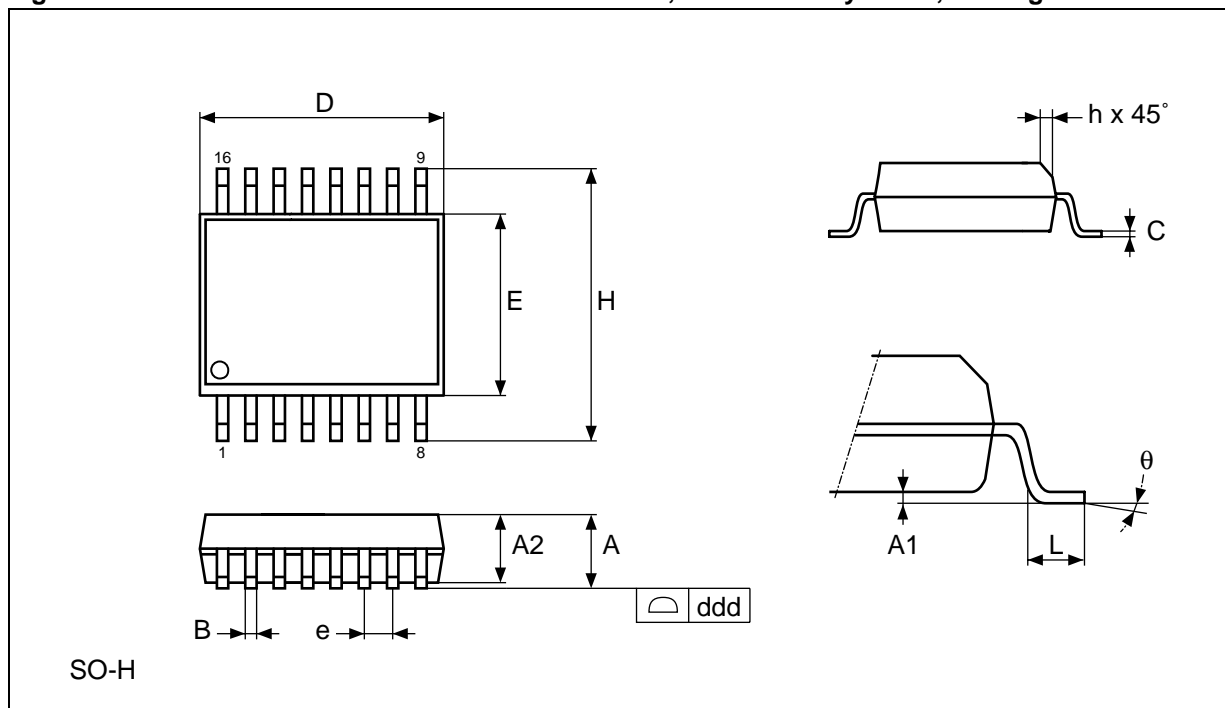

Note: Drawing is not to scale.

Table 16. SO16 wide – 16-lead Plastic Small Outline, 300 mils body width, Mechanical Data

| Symb. | mm | | | inches | | |
|-------|------|-------|-------|--------|-------|-------|
| | Typ. | Min. | Max. | Typ. | Min. | Max. |
| A | | 2.35 | 2.65 | | 0.093 | 0.104 |
| A1 | | 0.10 | 0.30 | | 0.004 | 0.012 |
| B | | 0.33 | 0.51 | | 0.013 | 0.020 |
| C | | 0.23 | 0.32 | | 0.009 | 0.013 |
| D | | 10.10 | 10.50 | | 0.398 | 0.413 |
| E | | 7.40 | 7.60 | | 0.291 | 0.299 |
| e | 1.27 | – | – | 0.050 | – | – |
| H | | 10.00 | 10.65 | | 0.394 | 0.419 |
| h | | 0.25 | 0.75 | | 0.010 | 0.030 |
| L | | 0.40 | 1.27 | | 0.016 | 0.050 |
| q | | 0 | 8 | | 0 | 8 |
| ddd | | | 0.10 | | | 0.004 |

PART NUMBERING

Table 17. Ordering Information Scheme

| Example: | M25P16 | – | V | ME | 6 | T | P |
|---|--------|---|---|----|---|---|---|
| Device Type M25P = Serial Flash Memory for Code Storage | | | | | | | |
| Device Function 16 = 16Mbit (2M x 8) | | | | | | | |
| Operating Voltage V = V _{CC} = 2.7 to 3.6V | | | | | | | |
| Package MF = SO16 (300 mil width) ME = VDFPN8 8x6mm (MLP8) | | | | | | | |
| Device Grade 6 = Industrial temperature range, –40 to 85 °C. Device tested with standard test flow | | | | | | | |
| Option blank = Standard Packing T = Tape and Reel Packing | | | | | | | |
| Plating Technology blank = Standard SnPb plating P ¹ = Lead-Free and RoHS compliant G ² = Lead-Free, RoHS compliant, Sb ₂ O ₃ -free and TBBA-free | | | | | | | |

Note: 1. Available for SO16 package only
2. Available for MLP package only

For a list of available options (speed, package, etc.) or for further information on any aspect of this

device, please contact your nearest ST Sales Office.

REVISION HISTORY

Table 18. Document Revision History

| Date | Rev. | Description of Revision |
|-------------|------|--|
| 16-Jan-2002 | 0.1 | Target Specification Document written |
| 23-Apr-2002 | 0.4 | Clarification of descriptions of entering Stand-by Power mode from Deep Power-down mode, and of terminating an instruction sequence or data-out sequence. ICC2(max) value changed to 10 μ A |
| 13-Dec-2002 | 0.5 | Typical Page Program time improved. Write Protect setup and hold times specified, for applications that switch Write Protect to exit the Hardware Protection mode immediately before a WRSR, and to enter the Hardware Protection mode again immediately after |
| 15-May-2003 | 0.6 | MLP8 package added |
| | 0.7 | 50MHz operation, and RDID instruction added. Published internally, only |
| 20-Jun-2003 | 0.8 | 8x6 MLP8 and SO16(300 mil) packages added |
| 24-Sep-2003 | 1.0 | t_{PP} , t_{SE} and t_{BE} revised. SO16 package code changed. Output Timing Reference Voltage changed. Document promoted to Preliminary Data. |
| 24-Nov-2003 | 2.0 | Table of contents, warning about exposed paddle on MLP8, and Pb-free options added. Value of $t_{VSL}(\min)$ and $t_{BE}(\text{typ})$ changed. Change of naming for VDFPN8 packages. Document promoted to full Datasheet. |
| 17-May-2004 | 3.0 | MLP8(5x6) package removed. Soldering temperature information clarified for RoHS compliant devices. Device Grade clarified |

Information furnished is believed to be accurate and reliable. However, STMicroelectronics assumes no responsibility for the consequences of use of such information nor for any infringement of patents or other rights of third parties which may result from its use. No license is granted by implication or otherwise under any patent or patent rights of STMicroelectronics. Specifications mentioned in this publication are subject to change without notice. This publication supersedes and replaces all information previously supplied. STMicroelectronics products are not authorized for use as critical components in life support devices or systems without express written approval of STMicroelectronics.

The ST logo is a registered trademark of STMicroelectronics.

All other names are the property of their respective owners.

© 2004 STMicroelectronics - All rights reserved

STMicroelectronics GROUP OF COMPANIES

Australia - Belgium - Brazil - Canada - China - Czech Republic - Finland - France - Germany -
Hong Kong - India - Israel - Italy - Japan - Malaysia - Malta - Morocco - Singapore -
Spain - Sweden - Switzerland - United Kingdom - United States

www.st.com

This datasheet has been download from:

www.datasheetcatalog.com

Datasheets for electronics components.